

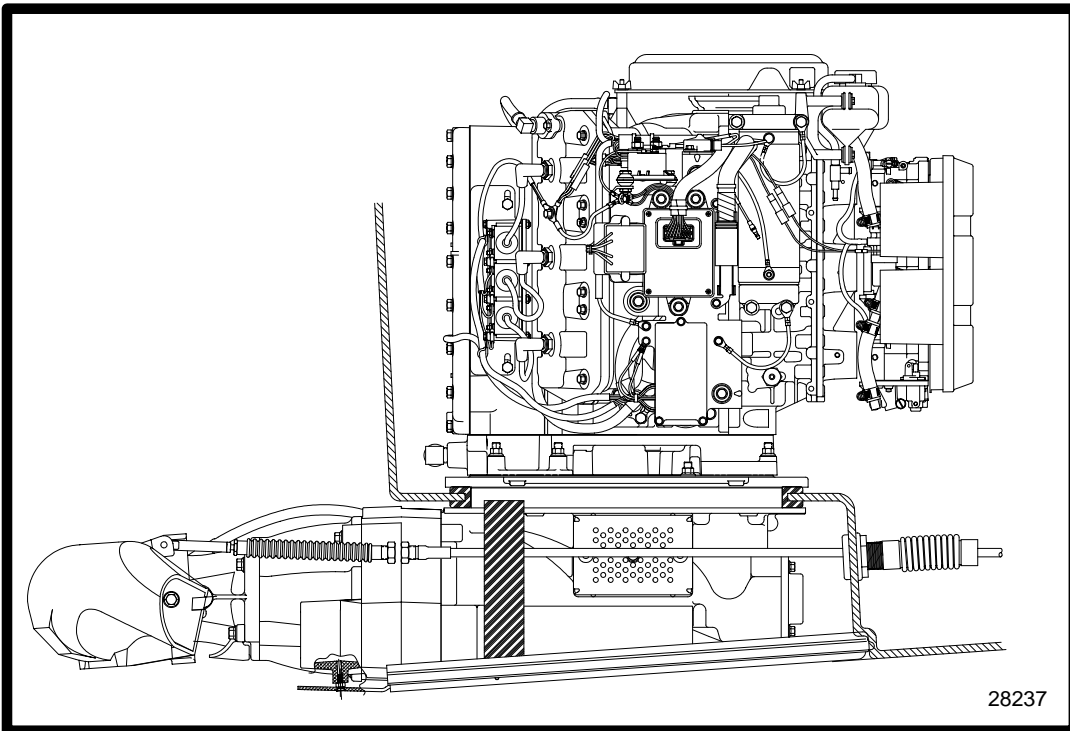

JET PUMP



28237

5



Table Of Contents

	Page
General Information	5-1
Principles Of Operation	5-1
Special Tools	5-2
Drive Housing Components	5-4
Pinion & Impeller Shaft	5-6
Nozzle/Rudder Components	5-8
Servicing Stator, Impeller And Wear Ring	5-10
Disassembly	5-10
Removing Reverse Gate, Rudder And Nozzle As An Assembly	5-10
Stator Removal	5-10
Impeller Removal	5-11
Inspecting Components	5-11
Installing Impeller	5-11
Removing Jet Drive From Boat	5-12
Drive Housing Disassembly And Reassembly	5-13
Pinion Shaft Removal	5-13
Impeller Shaft Removal	5-14
Shimming Procedures	5-17



General Information

NOTE: Due to running changes, some illustrations may not be exactly the same as your drive unit. Service procedures remain the same unless otherwise noted.

Principles of Operation

The jet pump operates by drawing water into a housing forward of the impeller. The water is pressurized within the specially designed housing and then directed to the rear to provide thrust and motion.

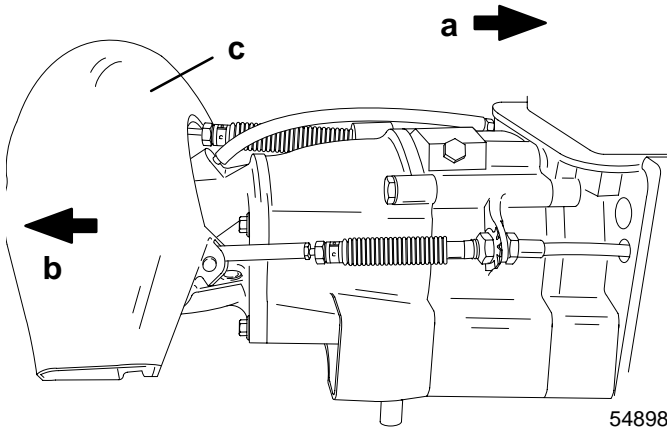

a - Forward Motion
b - Water Thrust

c - Reverse Gate
(Shown In the Forward Position)

The jet pump is equipped with a steerable nozzle (rudder) at the aft end of the pump housing that directs the thrust of water. The jet of water can be directed right or left when the operator turns the steering wheel in the respective direction. When the operator turns the steering wheel to the right, for example, the nozzle turns to the right and the jet force from the nozzle pushes the stern of the boat to the left causing the bow of the boat to turn right.

Forward and reverse drive and the neutral position are achieved by the position of a reverse gate located just aft of the nozzle. Forward drive has the reverse gate clearing the nozzle to allow all the thrust to be directed straight back. Reverse drive has the reverse gate covering the entire opening enough to divert the thrust forward. Neutral position has the reverse gate covering 75 percent of the nozzle to direct the water stream forward and downward, as well as backward. The shift position is controlled at the control box in the boat.

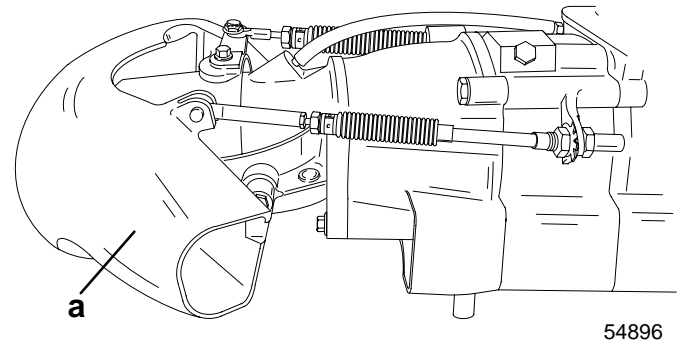

a - Reverse Gate (Shown In the Reverse Position)



Special Tools

Jet Pump Tool Kit 91-809957A1		
Description		Part Number
a	Pre-Load Kit Impeller Shaft	91-824871A2
b	Thread Extender Kit used w/ Backlash Kit	91-824869A1
c	Seal Protector Impeller Shaft	91-850233
d	Impeller Shaft Wrench	91-832093A1
e	Impeller Nut Socket	91-850297
f	Pinion Gear Location Tool	91-831897
g	Bearing Installer press ball bearing and seals into pinion shaft housing	91-832016
h	Bushing Installer stator bushings & seal	91-850831
i	Seal Installer impeller shaft seals in drive housing	91-832019
j	Bearing Installer impeller shaft ball bearing in drive housing	91-832017
k	Bearing Cup Installer pinion shaft housing and drive housing front cover	91-832018
l	Handle Driver	91-824892

Backlash Indicator Flag use MCII line	91-53459
Dial Indicator Kit	91-58222A1
Dial Indicator Adapter Kit	91-83155
Slide Hammer	91-34569A1
Bearing Puller Kit	91-83165M
Retaining Ring Pliers	91-25081
Lubricants/Adhesives	Part Number
Loctite, #271	92-809820
Loctite, #242	Obtain Locally
Perfect Seal	92-34227--1
2-4-C Lubricant w/ Teflon	92-825407A12
Special Lube 101	92-13872A1
Hi Performance Gear Lube	92-19007A24

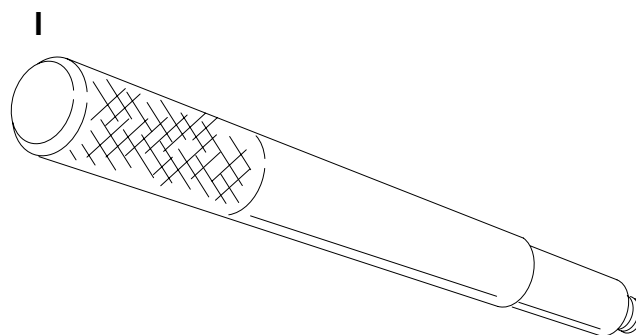
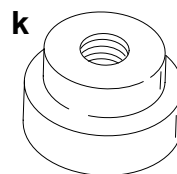
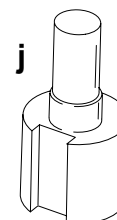
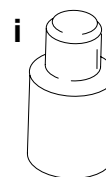
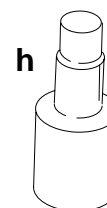
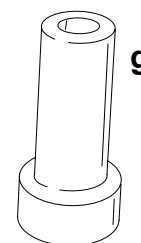
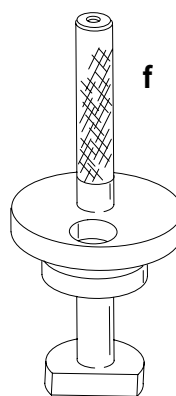
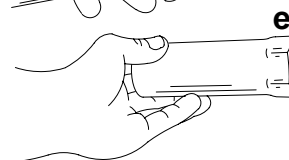
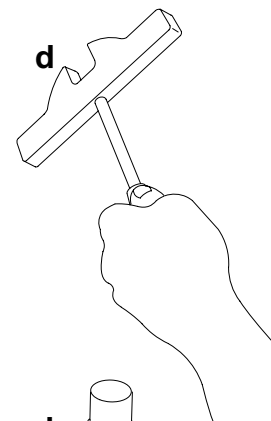
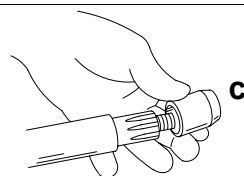
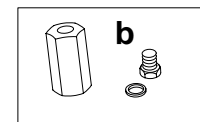
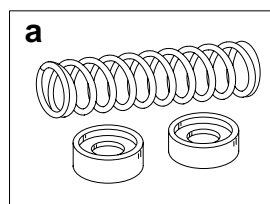



NOTES:





DRIVE HOUSING COMPONENTS

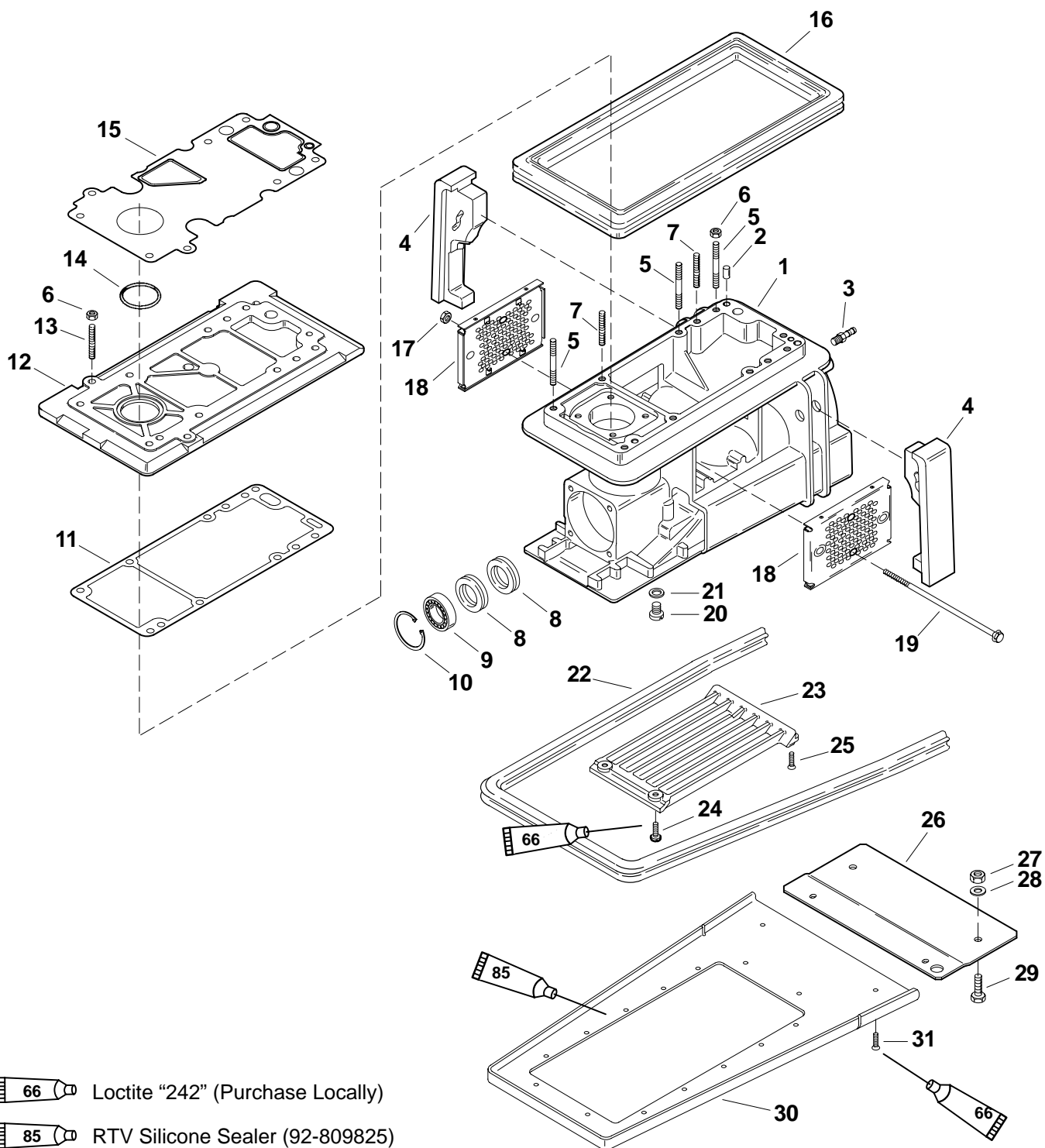



DRIVE HOUSING COMPONENTS

REF. NO.	QTY.	DESCRIPTION	TORQUE		
			lb. in.	lb. ft.	N-m
1	1	HOUSING ASSY-Drive (Basic) (Painted)			
2	1	PIN-Dowel			
3	1	FITTING-Syphon Drain Hose			
4	2	FOAM-Exhaust Deflector w/ 3-M #874 Adhesive			
5	6	STUD (M10 x 76) w/ 271 Loctite			
6	12	NUT (M10)		35	47
7	4	STUD (M10 x 55) w/ 271 Loctite			
8	2	SEAL-Oil			
9	1	BEARING-Ball			
10	1	RING-Snap			
11	1	GASKET-Drive Housing			
12	1	COVER ASSY W/Gaskets-Drive Housing (Painted)			
13	2	STUD (M10 x 66)			
14	1	O RING			
15	1	GASKET-Cover To Adapter Plate			
16	AR	GROMMET-Pump Mount (.250)			
	AR	GROMMET-Pump Mount (.375)			
	AR	GROMMET-Pump Mount (.500)			
17	1	NUT (M8)			
18	2	BAFFLE ASSEMBLY-Exhaust			
19	1	SCREW (M8 x 240))			
20	2	SCREW KIT			
21	2	WASHER-Sealing			
22	1	SEAL-Ride Plate, Self Locking			
23	1	SCREEN-Inlet (Painted)			
24	2	SCREW (M8 x 16) w/ Loctite 242	200		23
25	2	SCREW With Nylon Patch (M6 x 20) w/ Loctite 242	75		8.5
26	1	PLATE-Trim			
27	2	NUT (M8)			
28	2	WASHER			
29	2	SCREW (M8 x 35)		35	47
30	1	RIDE PLATE KIT (Painted)			
31	16	SCREW With Nylon Patch (M6 x 13) w/ Loctite 242	75		8.5



PINION & IMPELLER SHAFT

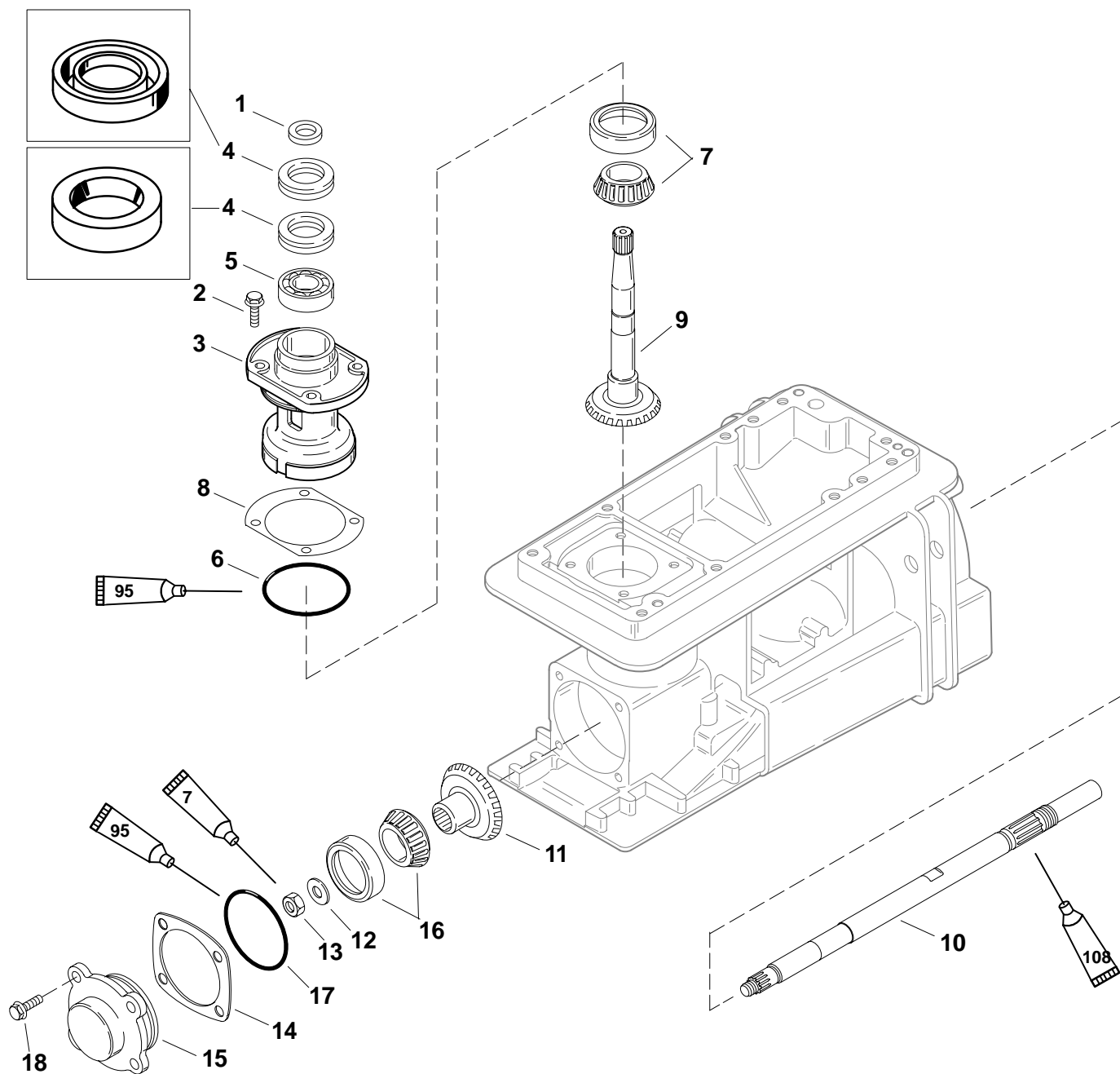

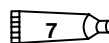
 Loctite "271" (92-809820)

 2-4-C w/Teflon (92-825407A12)

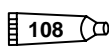
 Special Lubricant 101 (92-13872A1)



PINION & IMPELLER SHAFT

REF. NO.	QTY.	DESCRIPTION	TORQUE		
			lb. in.	lb. ft.	N-m
1	1	RING-Rubber			
2	4	SCREW (M8 x 25)	180		20.3
3	1	HOUSING ASSEMBLY-Pinion Shaft (Painted)			
4	2	SEAL-Pinion Shaft Housing			
5	1	BEARING-Ball			
6	1	BEARING SET			
7	1	O RING			
8	AR	SHIM (Red) (.002)			
	AR	SHIM (Beige) (.004)			
	AR	SHIM (Blue) (.005)			
	AR	SHIM (Frost/Clear) (.0075)			
	AR	SHIM (Brown) (.010)			
	AR	SHIM (Yellow) (.020)			
9	1	GEAR/SHAFT ASSEMBLY-Pinion			
10	1	SHAFT-Impeller			
11	1	GEAR-Impeller Shaft			
12	1	WASHER			
13	1	NUT (M14)		90	122
14	AR	SHIM (Red) (.002)			
	AR	SHIM (Beige) (.004)			
	AR	SHIM (Blue) (.005)			
	AR	SHIM (Frost/Clear) (.0075)			
	AR	SHIM (Brown) (.010)			
	AR	SHIM (Yellow) (.020)			
15	1	COVER ASSEMBLY-Impeller Shaft (Painted)			
16	1	BEARING SET			
17	1	O RING			
18	4	SCREW (M8 x 25)	180		20.3



NOZZLE/RUDDER COMPONENTS

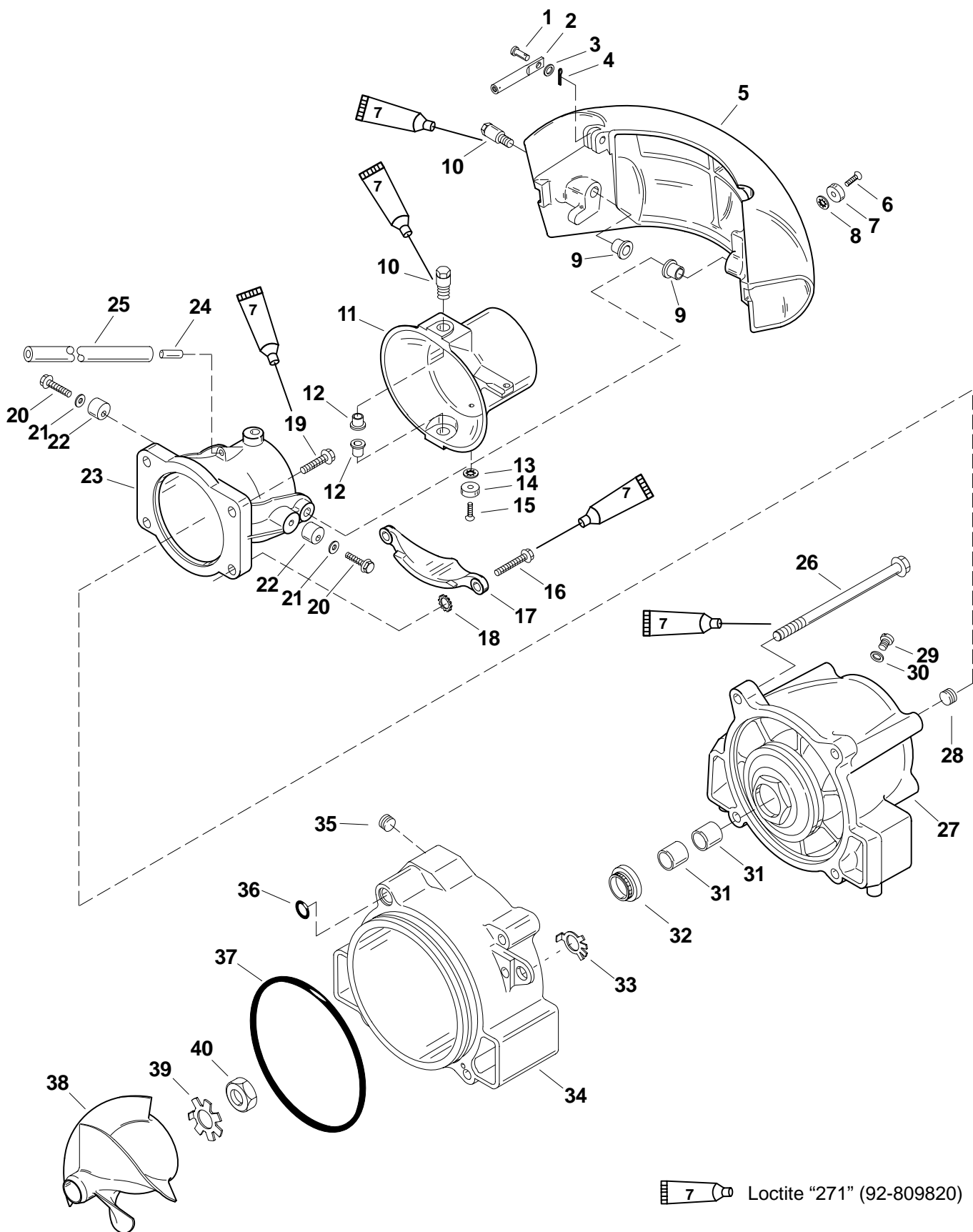



NOZZLE/RUDDER COMPONENTS

REF. NO.	QTY.	DESCRIPTION	TORQUE		
			lb. in.	lb. ft.	N-m
1	1	PIN-Clevis			
2	1	CONNECTOR-Cable End			
3	1	WASHER			
4	1	PIN-Cotter			
5	1	GATE ASSEMBLY (Painted)			
6	1	SCREW (M6 x 13)			
7	1	ANODE			
8	1	LOCKWASHER (.250 Internal)			
9	2	BUSHING-Pivot			
10	4	BOLT-Pivot w/ Loctite 271		50	68
11	1	RUDDER KIT (Painted)			
12	2	BUSHING-Pivot			
13	1	LOCKWASHER (.250 Internal)			
14	1	ANODE			
15	1	SCREW (M6 x 13)			
16	2	SCREW (M10 x 45)		35	47
17	1	ANODE			
18	2	LOCKWASHER (.437 External)			
19	2	SCREW (M10 x 35)		35	47
20	2	SCREW (M8 x 30)	120		13.5
21	2	WASHER			
22	2	STOP-Reverse Gate			
23	1	NOZZLE ASSY-W/Pivot Bushings (Painted)			
24	1	FITTING-Nozzle			
25	1	HOSE-Syphon (12.00 In.)			
26	4	SCREW (M10 x 150)		35	47
27	1	STATOR ASSEMBLY (Painted)			
28	1	PLUG-Pipe			
29	1	SCREW KIT	50		5.6
30	1	WASHER-Sealing			
31	2	BUSHING-Stator Rear			
32	1	SEAL			
33	2	WASHER-Tab			
34	1	RING KIT-Wear (Painted)			
35	1	PLUG-Pipe (.750-14)			
36	1	O RING			
37	1	O RING			
38	1	IMPELLER KIT-SS-5 Blade			
39	1	TAB WASHER-Impeller Shaft			
40	1	NUT-Impeller Shaft		150	203



Servicing Stator, Impeller and Wear Ring

Disassembly

1. Disconnect spark plug leads from spark plugs.
2. Disconnect shift and steering cables at Reverse gate and Rudder.

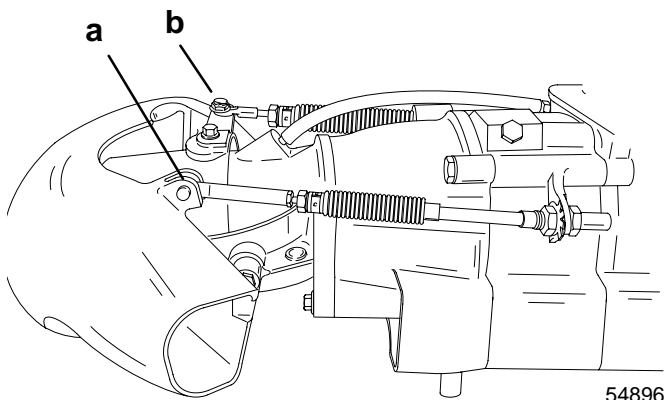

- a - Shift Cable
- b - Steering Cable

IMPORTANT: This procedure lists the disassembly of external pump components. If servicing a specific component, follow the procedure in that section.

REMOVING REVERSE GATE, RUDDER AND NOZZLE AS AN ASSEMBLY

3. Remove four screws securing nozzle to stator. Remove reverse gate/rudder/nozzle assembly.

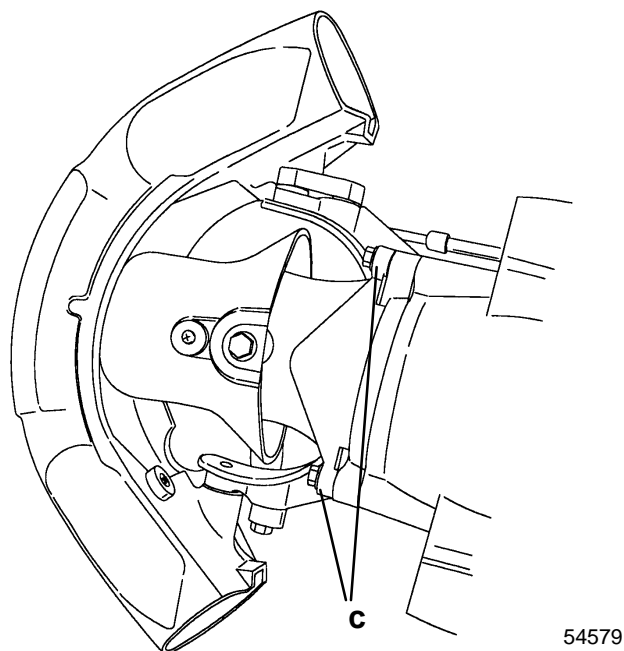

- c - Screws (4)

STATOR REMOVAL

4. Remove two screws securing trim plate to ride plate and wear ring.

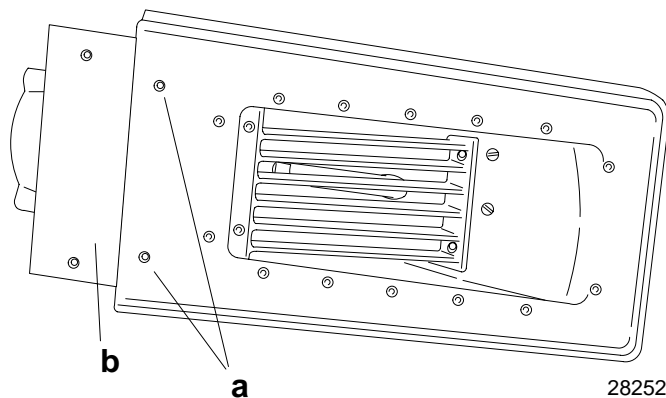

- a - Screws (2) to Trim Plate & Wear Ring
- b - Trim Plate

5. Remove four screws securing stator assembly to drive housing. Remove stator assembly.

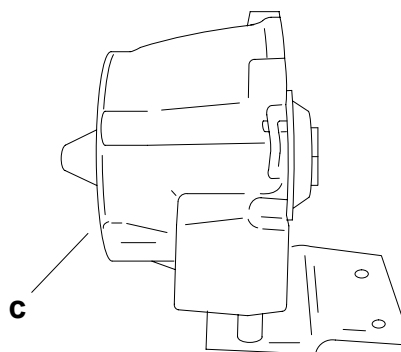

- c - Stator

6. Drain stator by tilting stator forward and allowing the oil to drain over the impeller shaft seals. Complete oil draining by removing stator fill screw and pour the remaining oil out the fill screw hole.



IMPELLER REMOVAL

7. If removed, install wear ring to support impeller and shaft during impeller removal.
8. Remove inlet screen on bottom of drive housing to allow access to machined flats on impeller shaft. If using Special Tool 91-832093A1 to hold impeller shaft, inlet screen does not need to be removed.
9. Straighten tabs on impeller tab washer.
10. While holding impeller shaft, remove impeller nut using Special Tool 91-850297. Impeller nut is a standard right hand thread. Remove impeller.

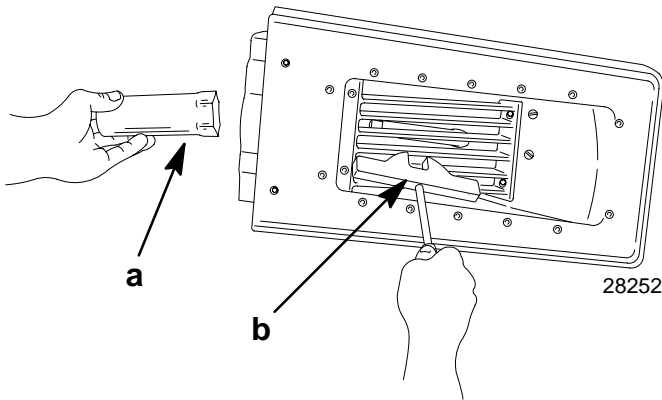

- a - Special Tool 91-850297
b - Special Tool 91-832093A1

11. Remove wear ring.

Inspecting Components

1. Inspect wear ring for excessive scoring and/or grooves. Replace wear ring if deep grooves are present or if severe scoring has taken place.
2. Ensure O-ring is in counterbore before installing wear ring to drive housing.

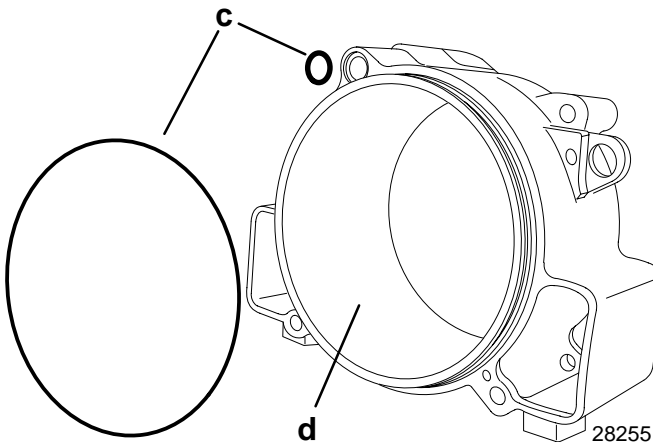

- c - O-rings
d - Inspect Surface for Grooves/Scoring

3. Inspect seal in stator for wear/damage.
4. Inspect bellows on cables for wear.
5. Inspect anodes, replace as necessary.
6. Inspect pivot pins and bushings, replace as necessary. Torque on reverse gate and rudder pivot pins is 50 lb. ft. (68 N·m). Use Loctite 271 on threads.
7. Inspect impeller for cracks and damaged blades.
8. Inspect stator vanes for cracks and/or damage.
9. If replacement is required, remove stator seal using Puller 91-83165M.

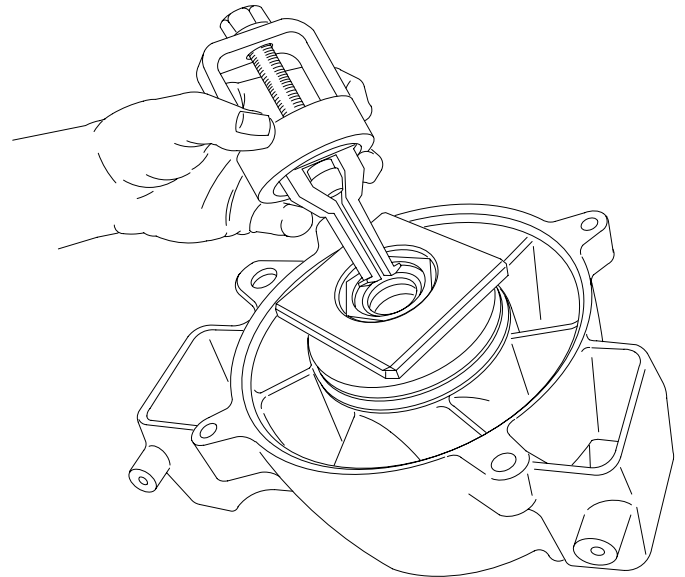

10. Install new seal using Special Tool 91-850831. Smaller diameter seal lip faces out.

Installing Impeller

1. Lubricate splines of impeller shaft with Special Lube 101 (92-13872A1).
2. Install impeller, tab washer and nut on impeller shaft. Locate bent tab in impeller slot. Torque impeller nut to 150 lb. ft. (203 N·m). Bend one tab against flat on nut.
3. Install inlet screen. Apply Loctite 242 to threads of screws and bolts. Torque the two 6 mm screws to 75 lb. in. (8.5 N·m). Torque the two 8 mm bolts to 200 lb. in. (22.5 N·m).
4. Install wear ring and stator. Apply Perfect Seal to threads of four bolts. Torque to 35 lb. ft. (47 N·m).



- Remove stator fill screw with washer and fill stator with High Performance Gear Lube (92-13783A24) until oil flows out fill hole (capacity is 19 fl. oz. / 550 cc). Install fill screw and washer.

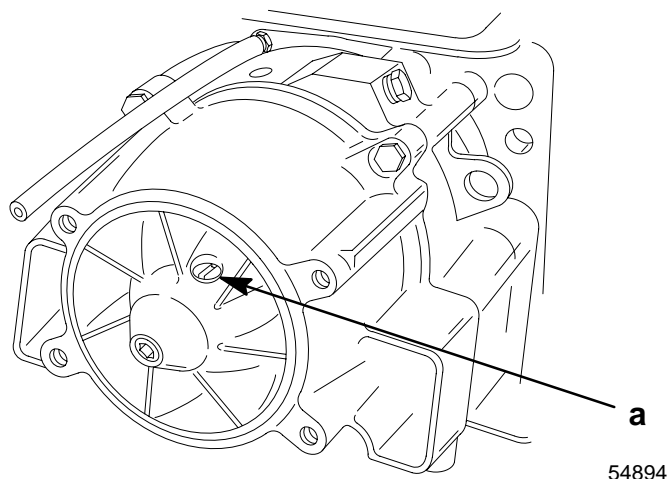

a - Fill Screw

- Apply Loctite 242 to screws (2) securing trim plate to the ride plate. Torque screws to 75 lb. in. (8.5 N·m).

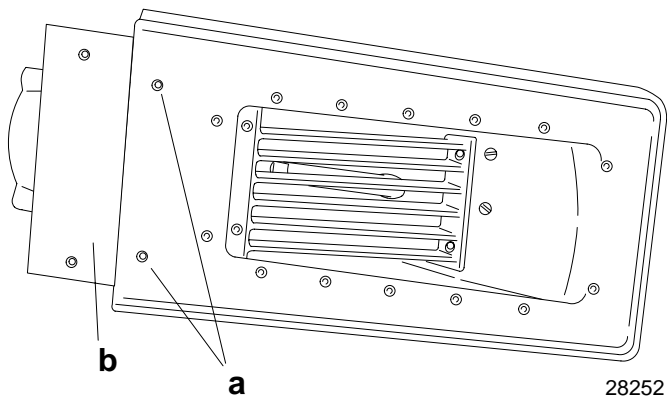

a - Screws (2) to Trim Plate & Wear Ring

b - Trim Plate

- Install nozzle assembly and anode. Apply Loctite 271 to threads of screws. Torque all four (4) screws to 35 lb. ft. (47 N·m).

- Attach shift and steering cables.

REFER TO SECTION 1D: SPORT JET INSTALLATION FOR SHIFT AND STEERING INSTALLATION AND ADJUSTMENT.

Removing Jet Drive From Boat

REMOVE POWERHEAD AS OUTLINED IN SECTION 4.

- Disconnect shift and steering cables from reverse gate and rudder. Remove cable adaptors and bellows assemblies. Loosen shift and steering cables at wear ring.

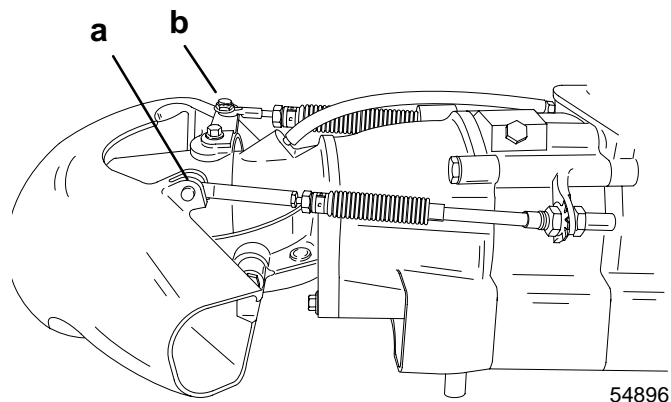

a - Shift Cable

b - Steering Cable

- Loosen shift and steering cable thru hull fittings.

- Support pump.

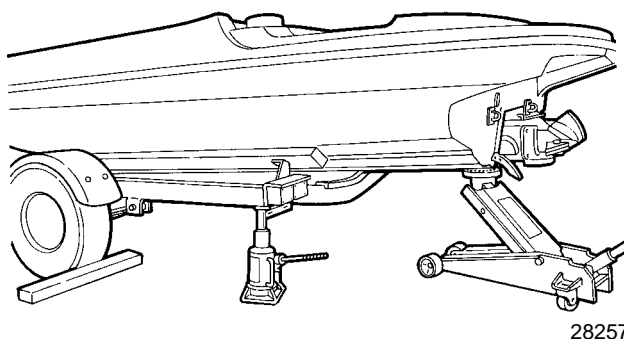

⚠ WARNING

The pump unit must be supported to prevent it from dropping through the opening when the remaining fasteners are removed.

- Remove remaining four nuts from drive housing cover. Remove drive housing cover and gasket.

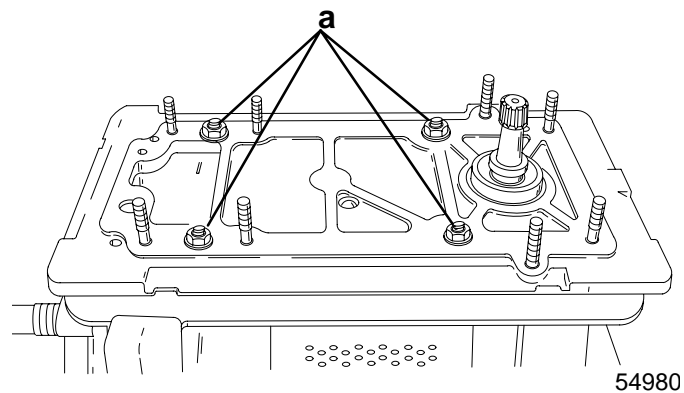

a - Nuts (4)



5. Lower drive housing while sliding cables out. Place on bench or suitable work stand for disassembly/repair.

Drive Housing Disassembly and Reassembly

Pinion Shaft Removal

1. Remove four screws securing pinion shaft housing to drive housing. Remove pinion shaft assembly.

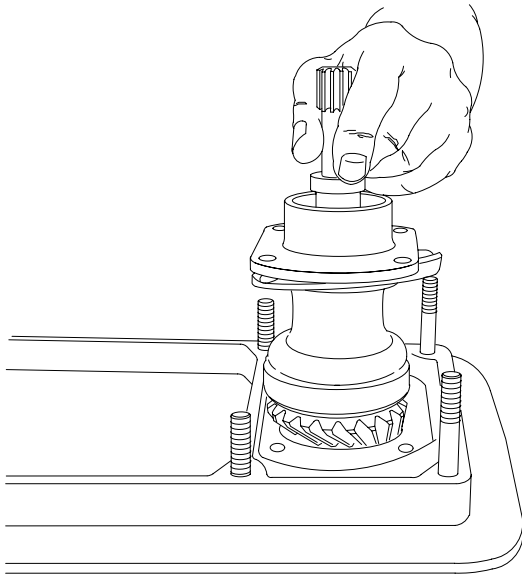

28257

NOTE: Take care not to damage or misplace colored shims.

2. Remove rubber ring, O-ring and shims.

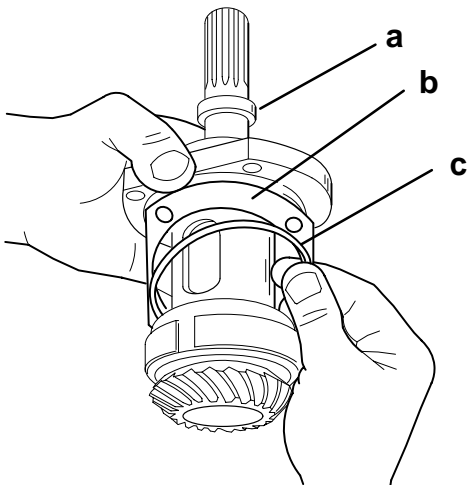

53797

- a - Rubber Ring
- b - Shims
- c - O-ring

3. Press pinion shaft out of pinion shaft housing.

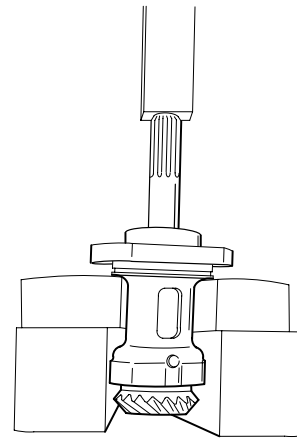

53796

4. Remove pinion shaft ball bearing and two seals using Puller 91-83165M.

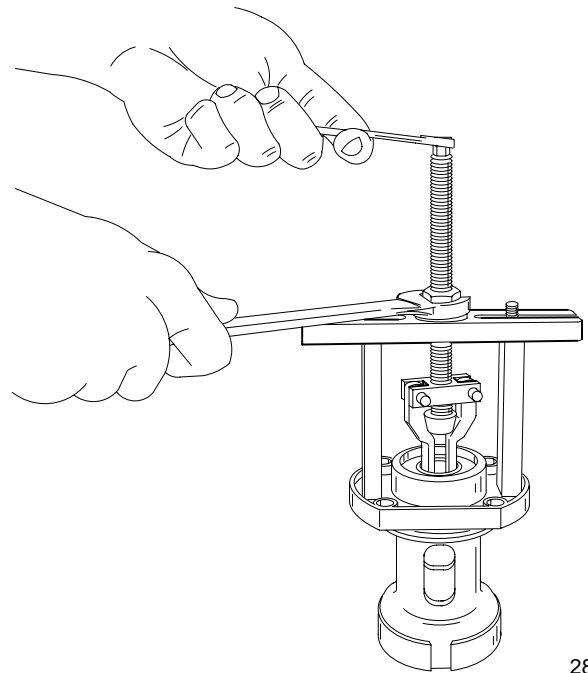

28264

5. Remove pinion shaft outer race from pinion shaft housing using slide hammer 91-34569A1.

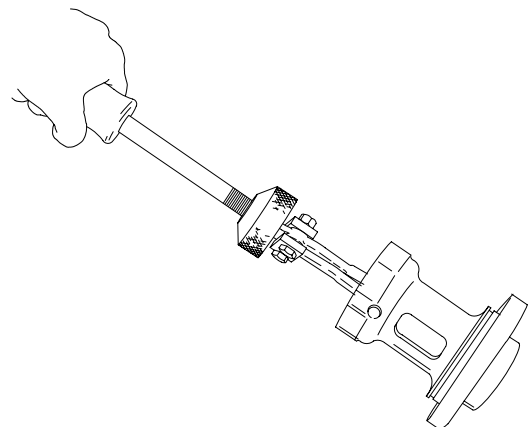

28265



6. Press new outer race into pinion shaft housing using mandrel 91-832018.

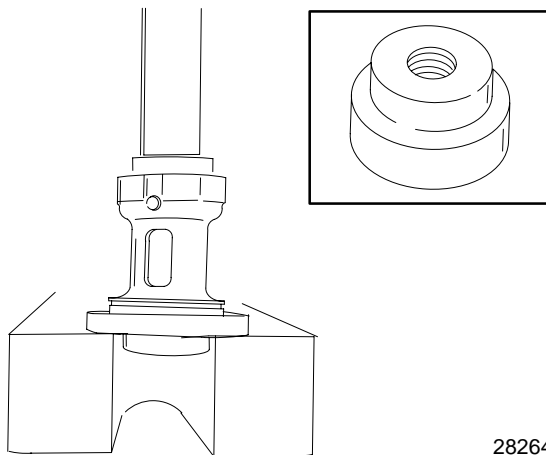

7. Remove tapered roller bearing from pinion shaft using universal puller plate 91-37241.
8. Press new tapered roller bearing onto pinion shaft using Special Tool 91-827983.

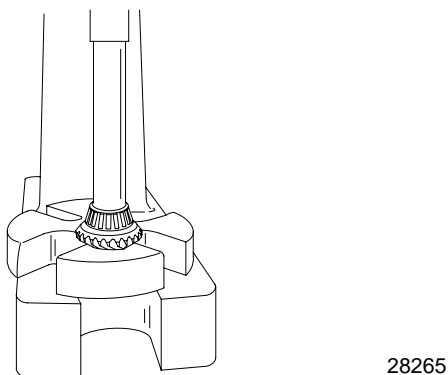

9. Press new ball bearing into pinion shaft housing using Special Tool 91-832016.

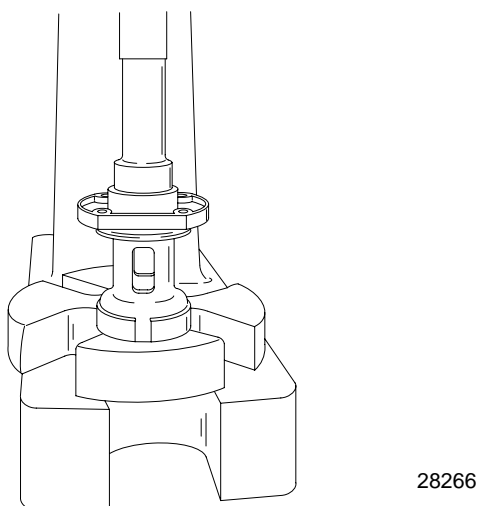

10. Press pinion shaft into pinion housing.

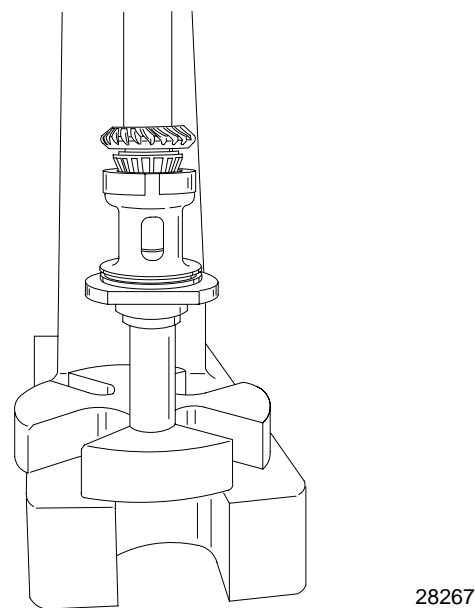

11. Press new seals into pinion shaft housing, one at a time, using Special Tool 91-820552. Inner seal faces in, outer seal faces out.

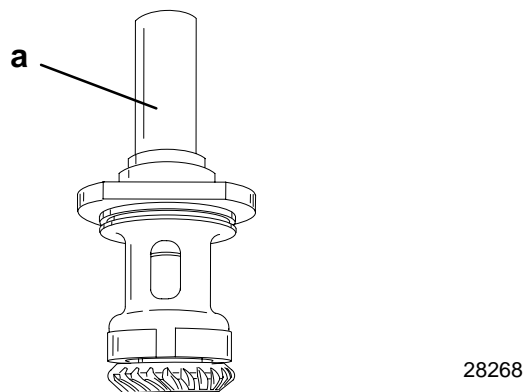

a - Special Tool 91-820552

Impeller Shaft Removal

1. Remove Stator, Wear Ring and Impeller as described in "Servicing Impeller".
2. Remove stator fill screw, drain oil into a suitable container.
3. Remove ride plate.



4. Remove four screws securing impeller shaft cover to drive housing. Remove cover.

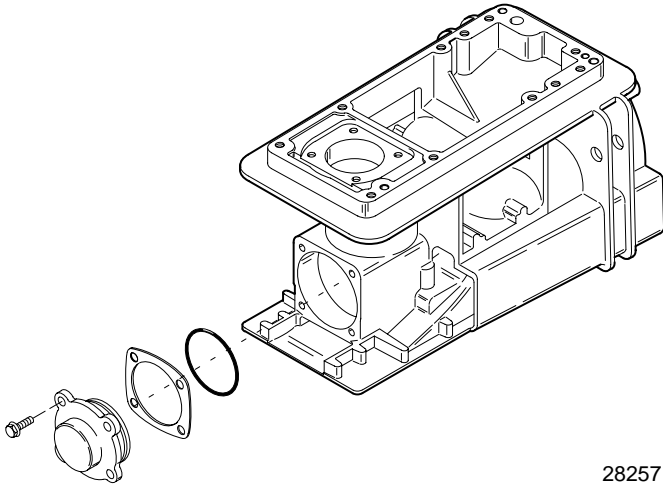

28257

NOTE: Take care not to damage or misplace colored shims.

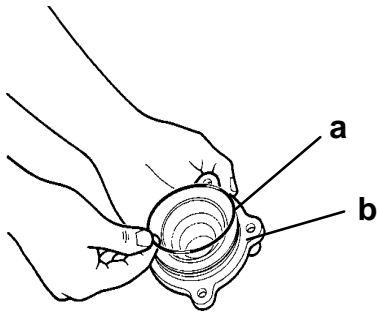

28258

a - O-ring
b - Shims

5. Remove nut and washer from end of impeller shaft. Remove impeller shaft gear.

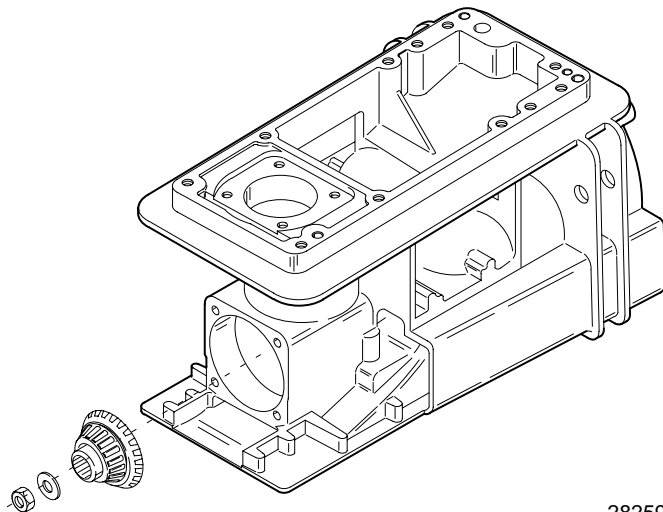

28259

6. Pull impeller shaft from drive housing.

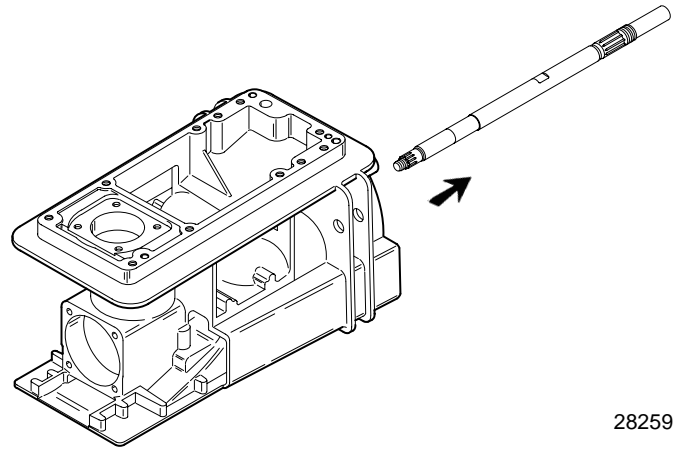

28259

7. Remove bearing retaining ring from drive housing.

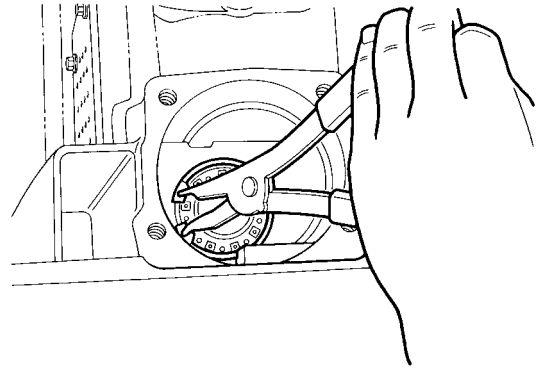

28262

8. Remove bearing using Puller 91-83165M.

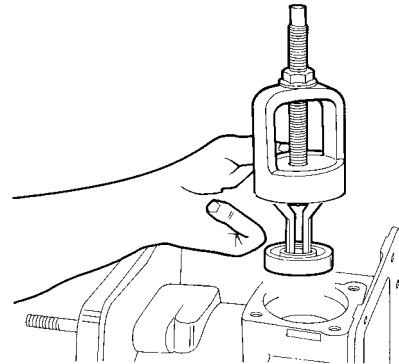

28263

9. Remove impeller shaft seals using Slide Hammer 91-34569A1.



10. Install new seals using Special Tool 91-832019.

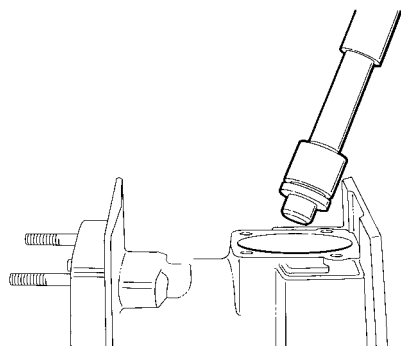

28260

11. Install new bearing using Special Tool 91-832017.

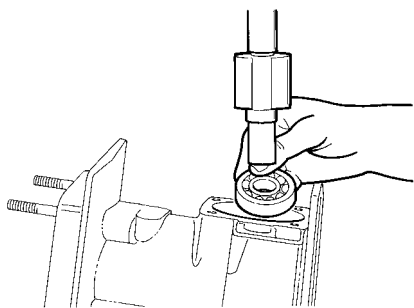

28261

12. Install retaining ring in drive housing after bearing is installed.

13. If replacing impeller shaft gear bearing, remove using universal plate.

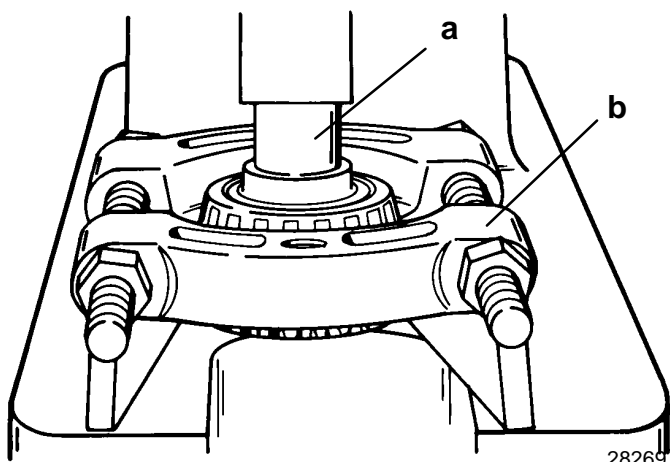

28269

a - Suitable Mandrel

b - Universal Plate

14. Press new bearing on gear using an appropriate size mandrel.

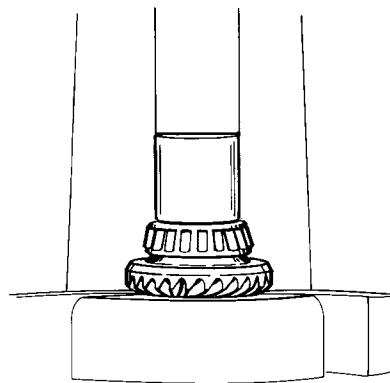

28270

15. If replacing bearing, remove outer race from front cover using slide hammer. Press new outer race in cover using suitable mandrel.

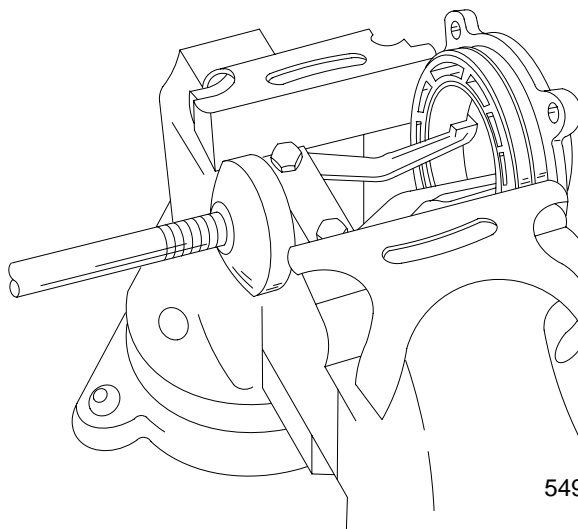

54985



Shimming Procedures

NOTE: Pinion gear shimming and backlash procedures must be performed when any of the following components have been replaced:

- Jet Drive Housing
- Pinion Gear
- Pinion Gear Bearing Assembly
- Pinion Shaft Housing
- Impeller Gear
- Impeller Gear Bearing Assembly
- Impeller Shaft Front Cover

NOTE: Shims are color coded to represent different thicknesses. These color codes apply to both pinion housing shims and impeller cover shims.

Red	.002 in. (.05 mm)
Beige	.004 in. (.10 mm)
Blue	.005 in. (.127 mm)
Frost (Clear)	.0075 in. (.19 mm)
Brown	.010 in. (.25 mm)
Yellow	.020 in. (.51 mm)

- Install original shims on pinion shaft housing. Install O-ring on pinion shaft housing.

NOTE: If original shims are not available, start with .030 in. (.76 mm) shims (three brown colored shims).

- Install pinion shaft assembly into drive housing bore. Torque screws to 180 lb. in. (20.3 N·m).

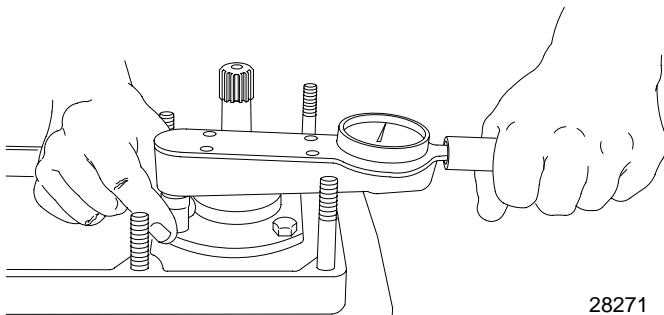

28271

- Rotate pinion shaft ten revolutions to properly seat roller bearings.
- Insert Pinion Location Tool (Special Tool 91-824890) in drive housing.

NOTE: Carefully inspect location tool to make sure it is seated in drive housing bearing.

- Insert feeler gauge through hole in pinion location tool between gauging surface of tool and flats on bottom of pinion gear teeth.

IMPORTANT: The correct clearance is .025 inch (0.64 mm).

- Use .025 inch (.064 mm) feeler gauge as a starting thickness. Adjust thickness of feeler gauge until a slight drag is felt as gauge is drawn out between gauging surface of tool and pinion gear.

NOTE: Once the thickness is determined, the difference between feeler gauge thickness and .025 inch (0.64mm) required clearance must be either added or subtracted from the total thickness of shims between pinion shaft housing and drive housing.

- Remove the screws securing the pinion shaft housing assembly to the drive housing. Lift assembly out of the drive housing.
 - Adjust shim thickness as required.
- Install seal protector, Special Tool 91-850233, on impeller shaft. Install impeller shaft in drive housing, then remove seal protector.

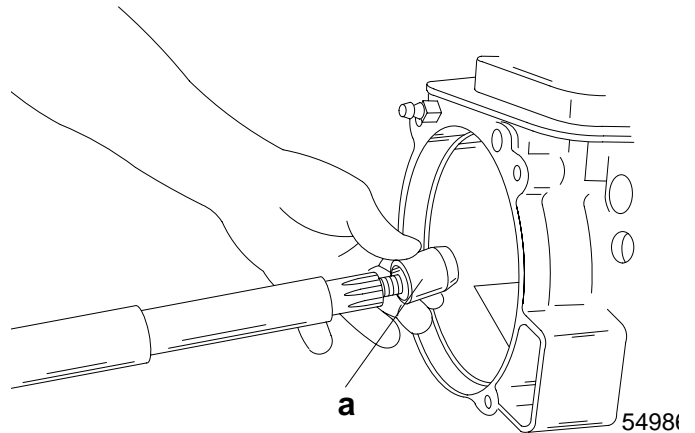

a - Seal Protector, Special Tool 91-850233



8. Install gear/bearing assembly and washer on impeller shaft. Apply Loctite 271 to threads of impeller shaft. Hold impeller shaft with Special Tool 91-832093A1. Install nut and torque to 90 lb. ft. (122 N·m).

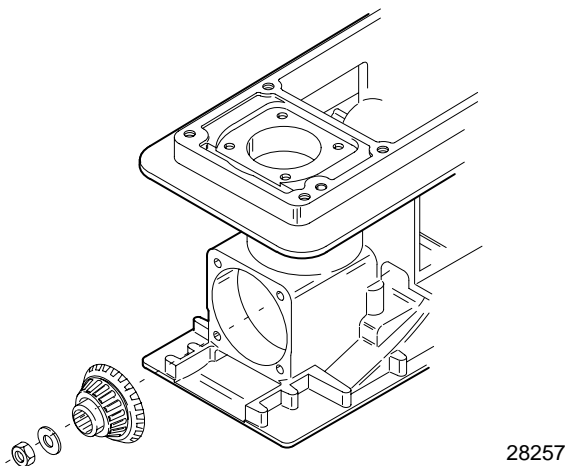

9. Install original shims on impeller shaft cover. Install O-ring on impeller shaft cover.

NOTE: If original shims are not available, start with .030 in. (.76 mm) shims (three brown colored shims).

- Lubricate O-ring and bore with Quicksilver lubricant 2-4-C.
- Lubricate cone bearing with gearcase lubricant.

10. Install impeller shaft cover. Torque screws to 180 lb. in. (20.3 N·m).

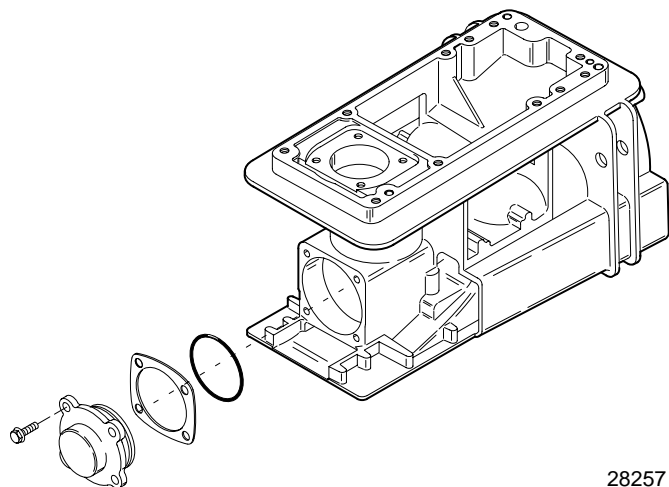

11. Install impeller shaft pre-load tool (91-824871A2).

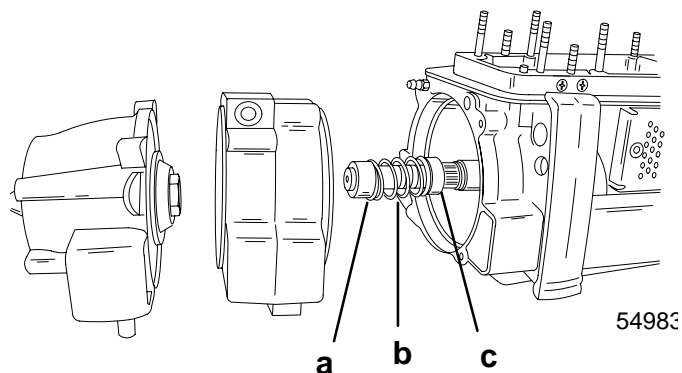

- a - Spring Seat, Rear
- b - Spring
- c - Spring Seat, Forward

12. Install wear ring and stator on impeller shaft. Secure assembly with two bolts (opposite corners). Torque bolts to 35 lb. ft. (47 N·m).

- Rotate impeller shaft ten revolutions to properly seat roller bearings.

13. Install Backlash Indicator Rod (Special Tool No. 91-53459) on pinion shaft.

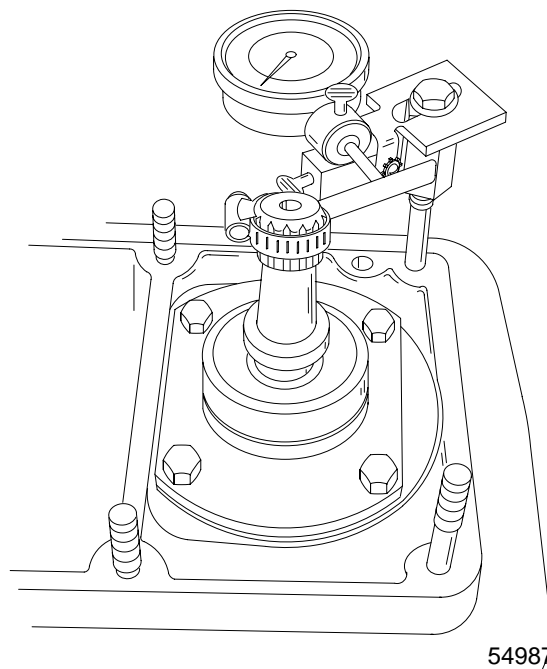

14. Install Dial Indicator Kit, Adapter Kit and Thread Extender Kit.

- Position rod from dial indicator on the center mark "II" of the backlash indicator rod.



15. Rotate pinion shaft back and forth lightly to contact gear teeth in each direction.

NOTE: Average total amount of reading of indicator backlash specification is .007 inch (.18 mm) to .009 inch (.23 mm).

- If reading is less than minimum, add shims between impeller cover and drive housing.
- If reading is more than maximum remove shims between impeller cover and drive housing.
- Ratio of backlash reading to shims is 1:1.

16. Install impeller, wear ring and stator as outlined in "Installing Impeller" in this section.

17. Apply RTV Sealant (92-809825) on rideplate. Install rideplate. DO NOT reuse screws. Apply Loctite 242 to threads of new screws. Torque to 75 lb. in. (8.5 N·m).

18. Install nozzle/reverse gate assembly and anode. Apply Loctite #271 to threads of screws. Torque all four (4) screws to 35 lb. ft. (47 N·m).

19. Remove fill and vent screws from bottom of drive housing. Fill drive housing with High Performance Gear Lube. Capacity is 27 oz. (825 cc).

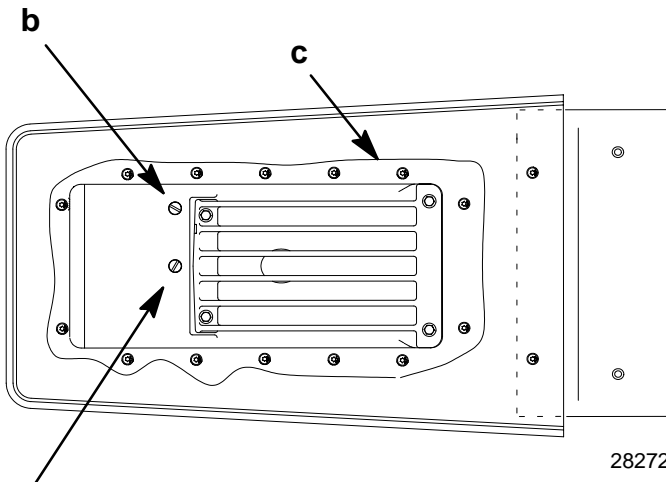

- a - Fill/Drain Screw
- b - Vent Screw
- c - RTV Sealant 92-809825

NOTE: To obtain correct oil level pump housing must be level and upright.

REFER TO SECTION 1D: SPORT JET INSTALLATION TO COMPLETE INSTALLATION OF DRIVE HOUSING, SHIFT AND STEERING CABLE INSTALLATION AND ADJUSTMENT.