



# FUEL SYSTEM

## Section 3E - Oil Injection

### Table of Contents

---

Operation of the Oil Injection System . . . . .	3E-2	Oil Injection Pump . . . . .	3E-13
Final Checks Before Operation Of Engine . . . . .	3E-2	Oil Pump Removal . . . . .	3E-13
Checking Operation Of The Oil Injection System (Engine Running) . . . . .	3E-3	Worm Bushing . . . . .	3E-14
Oil Injection Components . . . . .	3E-4	Worm Bushing Removal . . . . .	3E-14
Oil Injection Flow System . . . . .	3E-7	Worm Bushing Installation . . . . .	3E-14
Pump Drive Assembly . . . . .	3E-8	Oil Injection Pump Installation . . . . .	3E-15
Pump Drive System . . . . .	3E-8	Installing Drive Gear (for Oil Injection Pump) onto Crankshaft . . . . .	3E-15
Set Up Instructions for Oil Injection System . . . . .	3E-9	Oil Injection System Trouble Shooting Chart . . . . .	3E-16
Bleeding Air from Oil Injection Pump and Oil Injection Outlet Hose . . . . .	3E-11	Oil Pump Volume (Flow) Test . . . . .	3E-18
Adjusting Oil Injection Pump . . . . .	3E-12	Engine Mounted Oil Reservoir . . . . .	3E-19

---

**3  
E**

**⚠ CAUTION**

Be careful not to get dirt or other contamination in tanks, hoses or other components of the oil injection system during installation.

**⚠ CAUTION**

Engines with oil injection must be run on a fuel mixture of 50:1 for the first 30 gallons of fuel. Refer to engine break-in procedure in the Operation and Maintenance Manual.

**⚠ CAUTION**

If an electric fuel pump is to be used on engines with oil injection, the fuel pressure at the engine must not exceed 6 psi (41 kPa). If necessary, install a pressure regulator between electrical fuel pump and engine and set at 6 psi (41 kPa) maximum.

## Operation of the Oil Injection System

The oil injection system delivers oil mixture on engine demand, from 100:1 at idle to 50:1 at wide open throttle.

The remote oil tank can be removed from the boat for easy refilling. The remote tank holds enough oil for over 150 gallons of fuel at wide open throttle.

The remote oil tank supplies the oil reservoir mounted on the engine. The engine oil reservoir feeds the oil pump and contains enough oil for at least 30 minutes of full throttle running after the remote tank is empty. The warning horn will sound if the oil level in oil reservoir is low.

The oil injection pump feeds oil into the fuel just before the fuel pump. The oil injection pump is driven by the crankshaft and is connected to the throttle linkage for metering the varied flow of oil per engine RPM.

### Final Checks Before Operation Of Engine

- Make sure fill cap gaskets are in place and caps are tight on engine oil reservoir and remote oil tank.
- Mix a gasoline and oil mixture of 50:1 in the remote fuel tank during the initial break-in of the engine.
- Be certain the warning horn is installed and is operational. Refer to Instrument and Warning Horn Installation.
- Each time the key switch is turned from the “off” to “on” position (engine not running); the warning horn will sound momentarily. This tells you the warning system for the oil injection system is functional and the warning horn is operational. If warning horn does not sound or horn stays on when key is turned to the “ON” position, refer to oil injection system troubleshooting chart following to correct the problem.



## Checking Operation Of The Oil Injection System (Engine Running)

1. Operate engine following the break-in procedure outlined in the Operation and Maintenance Manual. If warning horn should sound an intermittent “beep,” “beep,” “beep” during operation, this indicates low oil level in the engine mounted oil reservoir. Refer to troubleshooting following, to correct the problem.
2. After engine has been run for a short time, check that no oil is leaking out of engine oil reservoir fill cap.





# Oil Injection Components

REF. NO.	QTY.	DESCRIPTION	TORQUE		
			lb-in	lb-ft	Nm.
–	1	OIL TANK			
1	1	OIL TANK			
2	1	CORD			
3	1	ADAPTOR HOUSING			
4	1	O RING			
5	1	CAP ASSEMBLY–oil tank			
6	1	O RING–cap			
7	1	TUBE–oil pick-up			
8	1	HOSE			
9	1	REMOTE OIL TANK HOLD-DOWN KIT			
10	1	BUNGY CORD ASSEMBLY			
11	1	OIL PUMP			
12	1	WORM BUSHING			
13	1	O-RING			
14	1	O RING			
15	1	BEARING ASSEMBLY–drive gear			
16	1	DRIVEN GEAR			
17	1	SCREW (10-32 x 5/8 IN.)	55		6
	1	SCREW (10-32 x 1-1/8 IN.)	55		6
18	1	LINK–throttle lever to oil pump			
19	1	FITTING–oil tubing			
20	1	PLUG			
21	1	TUBING–oil (6 IN.)			
22	1	OIL RESERVOIR			
23	3	SCREW–oil reservoir attaching (10-32 x 7/8)	25		3
24	6	WASHER–oil reservoir screw			
25	3	GROMMET–oil reservoir screw			
26	3	BUSHING–oil reservoir screw			
27	1	TUBING–oil reservoir to oil pump (4-3/4 IN.)			
28	AR	STA-STRAP			
29	1	CAP ASSEMBLY–oil reservoir			
30	1	FLOAT ASSEMBLY			
31	1	PUSHNUT			
32	1	GASKET–reservoir cap			
33	1	DECAL–Reservoir Warning			
34	1	HOSE			
35	2	FITTING			

AR = As Required



# Oil Injection Components

## ① REMOTE OIL TANK

Holds 3 gallons of oil.

The tank is pressurized by air from crankcase pressure thus forcing oil up the outlet hose to the oil reservoir on engine.

## ② OIL PICK UP TUBE

A filter screen is located in end of tube to prevent dirt or other particles from entering the system.

## ③ OIL RESERVOIR

The oil reservoir feeds the oil pump and contains enough oil for at least 30 minutes of full throttle running after the remote tank is empty. The warning horn will sound if the oil level in oil reservoir is low.

## ④ OIL INJECTION PUMP

Injection pump is driven off the crankshaft.

The oil injection pump is a variable metering pump. At idle the pump will meter the oil at approximately 100 to 1 gasoline to oil ratio and at WOT, 50 to 1 ratio.

## ⑤ 2 PSI CHECK VALVE

If oil flow to reservoir is obstructed and injection pump continues to pump oil, the 2 PSI valve will open to allow air to enter reservoir to prevent a vacuum.

## ⑥ 2 PSI CHECK VALVE

This valve prevents gasoline from being forced into the oil lines.

## ⑦ LOW OIL (FLOAT) SENSOR

If oil level drops in oil reservoir, the sensor will signal the warning module to sound the warning horn.

## ⑧ TKS ECM

- Sounds the warning horn briefly when key switch is turned on, to indicate that the system is operational.
- If oil level drops in the engine oil reservoir, the low oil (float) sensor will signal the module to sound the warning horn.



# Oil Injection Flow System

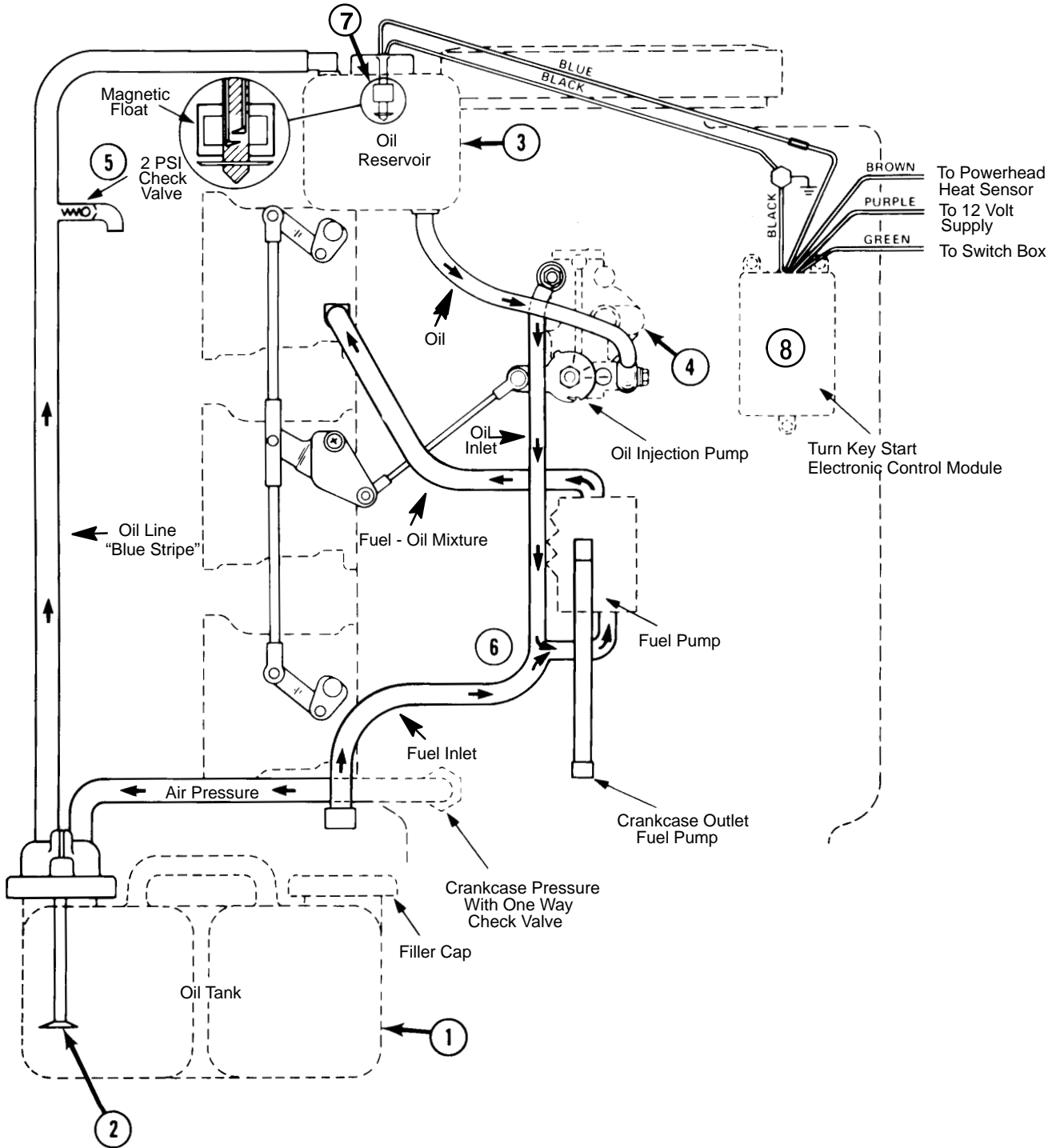



# Pump Drive Assembly

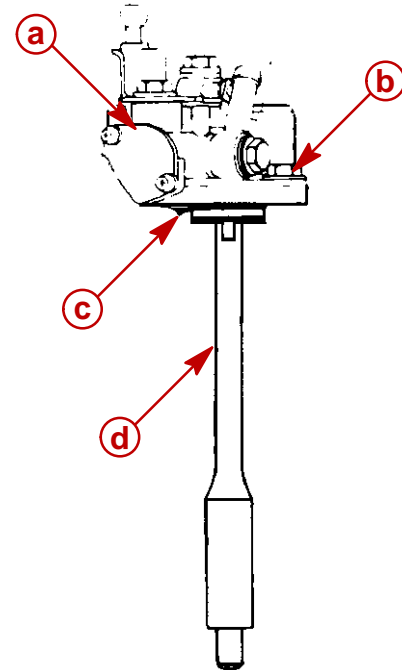
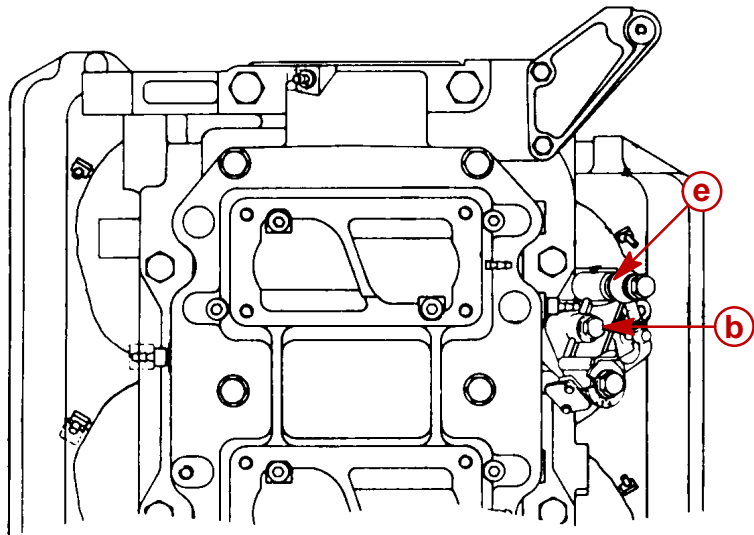

- a** - Oil Pump
- b** - Retaining Bolts (2)
- c** - O-ring

- d** - Driven Gear
- e** - Oil Pump (Installed)

# Pump Drive System

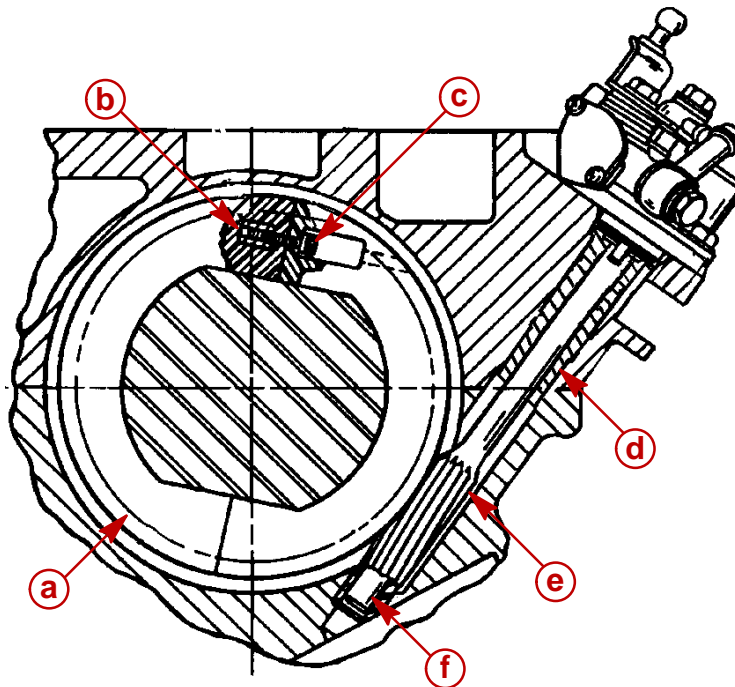

- a** - Drive Gear
- b** - Retaining Nut
- c** - Retaining Screw

- d** - Bushing
- e** - Driven Gear
- f** - Bushing





## Set Up Instructions for Oil Injection System

### ⚠ CAUTION

Be careful not to get dirt or other contamination in tanks, hoses or other components of the oil injection system during installation.

### ⚠ CAUTION

Oil injected engines additionally, must be run on a 50:1 gasoline/oil mixture in the fuel tank for the first 30 gallons of fuel. Refer to engine break-in procedures in the Operation & Maintenance Manual.

### ⚠ CAUTION

If an electric fuel pump is to be used on engines with oil injection, the fuel pressure at the engine must not exceed 6 psi (41 kPa). If necessary, install a pressure regulator between electrical fuel pump and engine and set at 6 psi (41 kPa) maximum.

## INSTALLING REMOTE OIL TANK

1. The remote oil tank should be installed in an area in the boat where there is access for refilling.

The tank should be restrained to keep it from moving around, causing possible damage.

An acceptable means of restraining the tank would be the use of eye bolts and an elastic retaining strap about the mid-section of the tank taking care that any metal hooks do not puncture the tank.

Keep in mind, when installing in tight areas, that this tank will be under pressure when the engine is operating and will expand slightly.

2. Oil hoses when routed thru engine well, must be able to extend to the hose fittings on engine.
3. Oil hoses must be arranged so they cannot become pinched, kinked, sharply bent or stretched during operation of the engine.

**NOTE:** An oil hose extension kit (41729A3) is available for the remote oil tank.

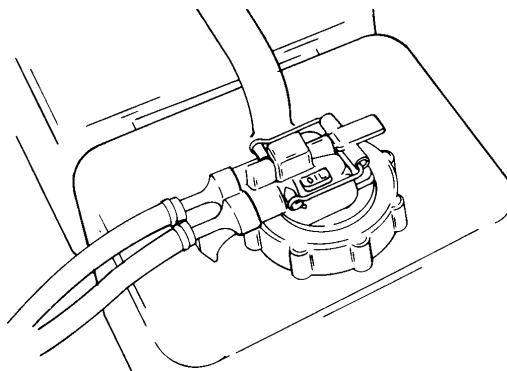

### Quick Disconnect Type Hose Connection

## INSTALLING OIL HOSES TO ENGINE

Route remote oil tank hoses to starboard side of engine.

4. Remove (and discard) the shipping cap from hose fitting (a).
5. Connect oil hose from remote oil tank (hose with blue stripe) to fitting (a). Secure with sta-strap.



**NOTE:** Fitting barb (b) is a vent and does not get connected to a hose.

6. Remove (and discard) shipping cap from pulse fitting (c).
7. Connect the second oil hose from remote oil tank to pulse fitting. Secure with strap.

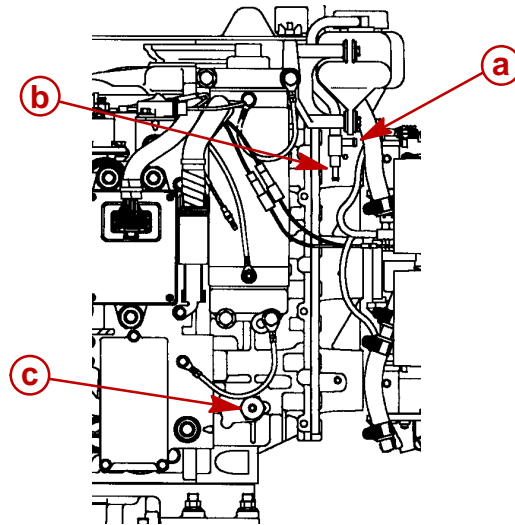

28237

**a** - Hose Fitting  
**b** - Vent

**c** - Pulse Fitting

## FILLING THE OIL INJECTION SYSTEM

**DO NOT USE Rotax Injection Oil in your Mercury M<sup>2</sup> Jet Drive.** This oil is not a NMMA Certified TC-W3 oil. Any failure caused from the use of this oil will not be covered under the limited warranty.

Mercury Marine recommends the use of "Mercury Precision Premium *Plus*" or "Quicksilver Premium *Plus*" 2-Cycle Oil NMMA Certified TC-W3.

The Premium *Plus* Oil is specially formulated and tested to not only maintain a high level of performance but also increase the durability of the engine. This special blend, developed by Mercury Marine, contains more than twice the additives used in standard blends and ensures the greatest protection for your engine.

Periodically consult with your dealer to get the latest gasoline and oil recommendations. If "Mercury Precision Premium *Plus*" or "Quicksilver Premium *Plus*" Outboard Oil is not available, you may substitute another brand of 2-Cycle outboard oil that is NMMA Certified TC-W3. Nationally recognized brands are recommended. Continued use of inferior 2-Cycle outboard oil can dramatically reduce engine life. Damage from use of inferior oils that are not NMMA Certified TC-W3 will not be covered under the limited warranty.

1. Fill remote oil tank with Mercury Precision or Quicksilver Premium Plus TCW-3 2-Cycle Oil. Tighten fill cap (a).

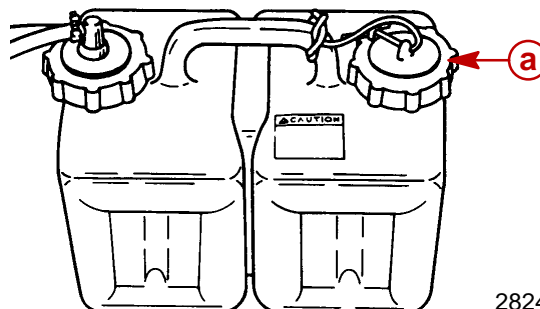

28243

**a** - Fill Cap



2. Remove fill cap (b) from the engine oil tank (c) and fill the tank with oil. Reinstall the fill cap.

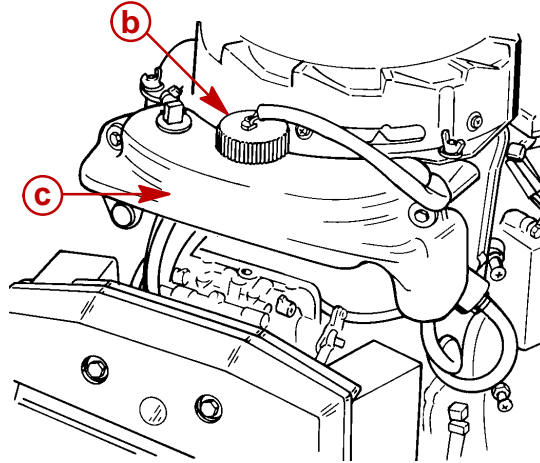

50047

- b** - Fill Cap
- c** - Engine Mounted Oil Reservoir

3. Loosen the fill cap (b) on the engine mounted oil tank. Run the engine until the all the air has been vented out of the tank and oil starts to flow out of the tank. Re-tighten fill cap.

**CAUTION**

Be certain that the fill caps on the engine oil tank and remote oil tank are installed tight. An air leak, at one of the caps on the remote oil tank, will prevent oil flow to the engine oil tank. A loose fill cap on the engine oil tank will cause oil leakage.

## Bleeding Air from Oil Injection Pump and Oil Injection Outlet Hose

### BLEEDING AIR FROM OIL INJECTION PUMP

With engine not running, place a shop towel below the oil injection pump. Loosen bleed screw three to four turns and allow oil to flow from bleed hole. Re-tighten bleed screw. This procedure allows the pump to fill with oil.

### BLEEDING AIR FROM OIL INJECTION PUMP OUTLET HOSE

Any air bubbles in outlet hose in most cases will be purged out of the system during operation of the engine.

**NOTE:** If air bubbles persist, they can be purged out of the hose by removing link rod and rotating the pump arm full clockwise while operating engine at 1000 to 1500 RPM: If necessary, gently pinch the fuel line between the fuel tank and the fuel pump "Tee" fitting. This



will cause the fuel pump to provide a partial vacuum which will aid in removal of the air. Reinstall link rod.

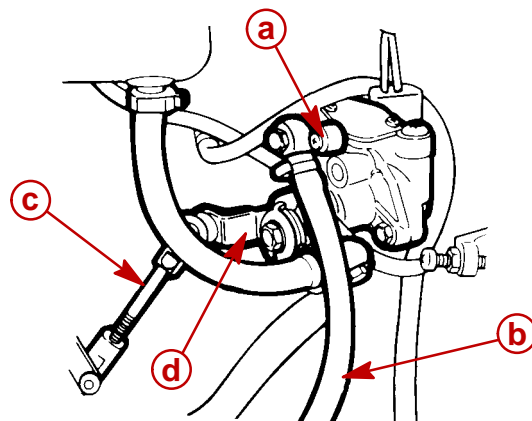

50047

- a** - Bleed Screw
- b** - Outlet Hose
- c** - Link Rod
- d** - Pump Arm

## Adjusting Oil Injection Pump

When throttle linkage is at idle position, alignment mark on oil injection arm should be in-line with mark on casting as shown. If necessary, adjust link rod.

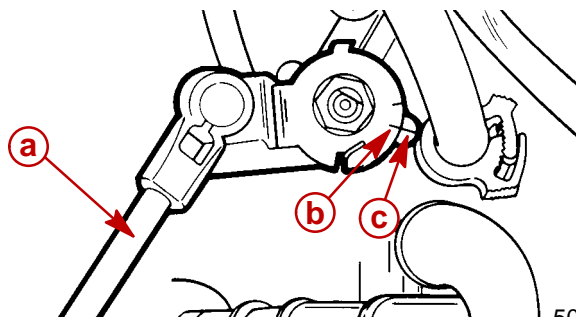

50060

- a** - Link Rod
- b** - Alignment Mark
- c** - Casting Mark

## OPERATION OF THE OIL INJECTION SYSTEM

1. Make sure fill cap gaskets or O-rings are in place and caps are tight on engine reservoir tank and remote oil tank.
2. Make sure the fuel tank has a gasoline and oil mixture of 50:1 during the initial break-in of the engine or after extended storage.
3. Be certain the warning horn is operational.

Each time the key switch is turned from the “off” to “on” position (engine not running); the warning horn will sound momentarily. This tells you the warning system for the oil injection system is functional and the warning horn is operational. If warning horn does not sound or horn stays on when key is turned to the “ON” position, refer to oil in injection system troubleshooting chart following to correct the problem.

The low oil injection warning sound is an intermittent four beeps with a 2 minute pause. The overheat warning sound is a continuous “beep” (not intermittent).



## CHECK OPERATION OF THE OIL INJECTION SYSTEM (ENGINE RUNNING)

1. Operate engine following the break-in procedure outlined in the Operation and Maintenance Manual. If warning horn should sound an intermittent “beep”, “beep”, “beep” during operation, this indicates a problem occurred in the oil injection system. Check that the oil level in the engine reservoir is full.
2. After engine has been run for a short time check that no oil is leaking out of engine mounted oil reservoir fill cap.

## Oil Injection Pump

### Oil Pump Removal

1. Disconnect and plug inlet hose to oil pump.
2. Disconnect outlet hose on oil pump.
3. Disconnect link arm from oil pump injection arm.
4. Remove two bolts securing oil pump to powerhead and remove pump.

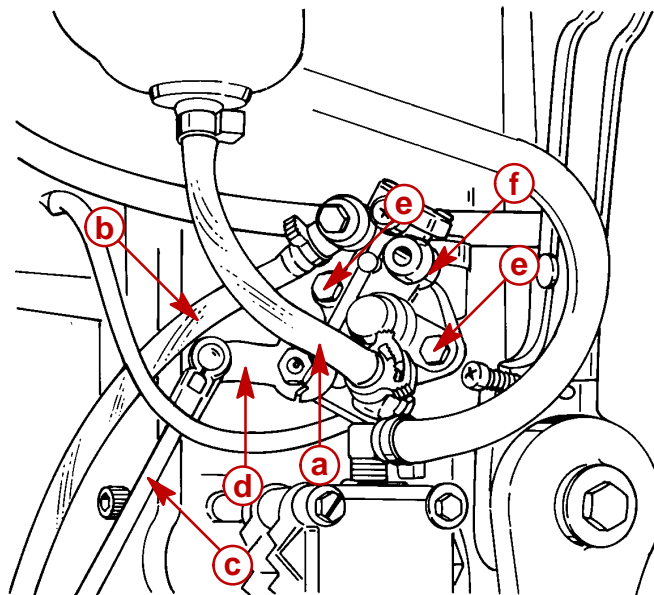

51892

- a** - Inlet Hose
- b** - Outlet Hose
- c** - Link Arm
- d** - Injection Arm
- e** - Bolts
- f** - Oil Pump



# Worm Bushing

## Worm Bushing Removal

1. Grasp bushing and remove from oil pump.

**NOTE:** If seal is defective, seal and bushing are replaced as an assembly.

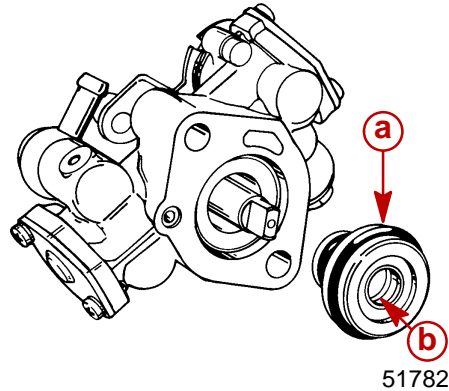

**a** - Bushing

**b** - Seal

## Worm Bushing Installation

**IMPORTANT:** If worm shaft is removed from oil pump with worm bushing, verify thrust washer is positioned in center of worm shaft pocket before reinstalling worm shaft.

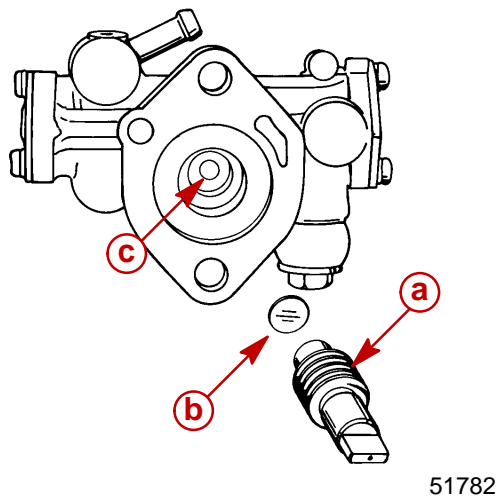

**a** - Worm Shaft

**b** - Thrust Washer

**c** - Pocket

1. Inspect bushing O-rings for cuts and abrasions. Replace O-rings if necessary.

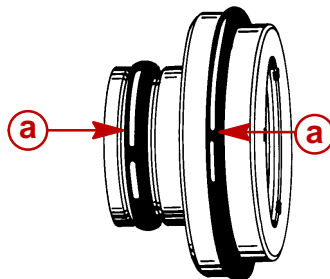

**a** - O-rings

51782

2. Reinstall bushing/seal assembly.



## Oil Injection Pump Installation

1. Align oil pump worm shaft with end of driven gear in powerhead.

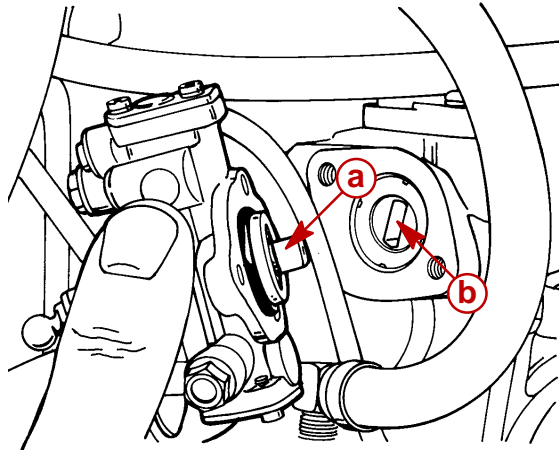

**a** - Worm Shaft

51782

**b** - Driven Gear

2. Apply Loctite 271 to threads of attaching bolts and secure oil pump to powerhead. Torque bolts to 55 lb. in. (6 N·m).
3. Connect inlet and outlet hoses to oil pump. Secure hoses with clamps.
4. Connect link arm to oil pump arm.
5. Prior to starting engine, refer to “**BLEEDING AIR FROM OIL INJECTION PUMP**” and “**ADJUSTING OIL INJECTION PUMP**,” SECTION 1D, for proper procedures.

## Installing Drive Gear (for Oil Injection Pump) Onto Crankshaft

**IMPORTANT:** Oil pump drive gear retaining screws **ARE STAKED** after installation. **DO NOT** remove drive gear from crankshaft unless gear is damaged or shows signs of excessive wear.

### REMOVAL OF DRIVE GEAR

1. Rotate crankshaft to gain access to two drive gear retaining allen screws.
2. Remove two screws and remove drive gear from crankshaft. **DO NOT** reuse retaining screws as screw threads may be damaged by factory staking process.

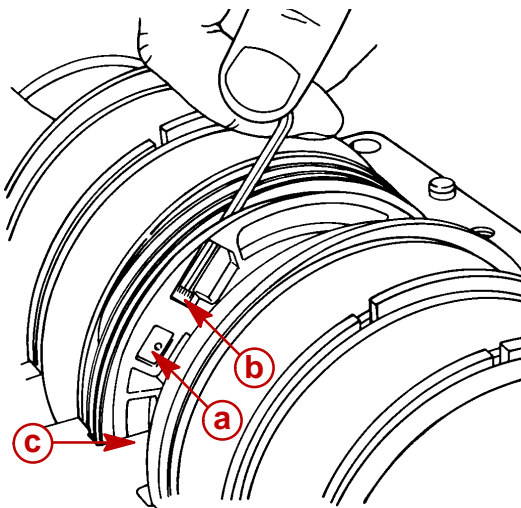

**a** - Retaining Nut  
**b** - Allen Screw

51892

**c** - Center Main Bearing  
(Hidden)



## INSTALLATION OF NEW DRIVE GEAR

1. Align drive gear halves on crankshaft with retaining screw access holes towards center main bearing.
2. Clean retaining screw threads with Loctite Primer T (92-59327-1). Apply Loctite 680 (obtain locally) to screw threads.
3. Secure drive gear halves together with retaining nuts and allen screws. Torque screws to 8 lb. in. (0.9 N·m)
4. Check gear halve split lines. Split should be drawn tight together (zero clearance) if gear halves are properly installed.

### ⚠ CAUTION

**Gear tooth mismatch at split line must not exceed 0.020 in. (0.50 mm) or gear failure will result.**

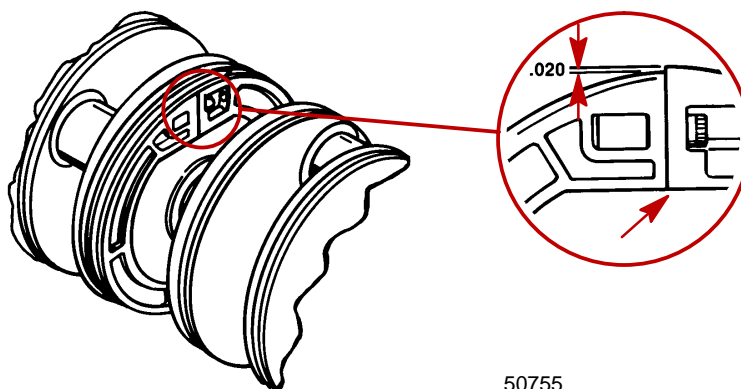

## Oil Injection System Trouble Shooting Chart

### TROUBLE SHOOTING THE OIL INJECTION SYSTEM

If a problem occurs with the oil injection system and the warning horn sounds in a pulsating manner, stop engine and check if problem is caused by low oil level.

1. Check oil level in engine reservoir tank. If oil level is not to the top of tank the problem is low oil level. There is a safety reserve of oil left in the reservoir after the low oil warning is sounded that allows you enough oil for 30 to 40 minutes of full throttle operation. Refer to trouble shooting chart to correct the problem.
2. If engine reservoir is full of oil, then the problem may be in the oil injection pump. DO NOT run engine on straight gas when a problem may be in the oil injection pump. Engine can be run by connecting a remote tank of 50:1 fuel and oil mixture to engine or in an emergency add (approx. a 50:1 ratio) of oil from the 3 gallon remote oil tank to the straight gas. Refer to trouble shooting chart to correct the problem.



**Problem: Oil Level in Engine Oil Reservoir Tank is Low But Not Low in Remote Oil Tank.**

Possible Cause	Corrective Action
Quick disconnect on remote oil tank is not fully connected	Reconnect
Remote oil hose (blue stripe) is blocked.	Check length of hose for a kink.
Remote pulse hose (second hose) is blocked or punctured.	Check length of hose for a kink.
Remote pulse hose check valve is faulty (this valve is located at the engine end of the hose).	Replace check valve.
A restricted oil outlet filter in the remote tank.	Remove filter and clean.
Leak at upper end of remote oil tank pick-up tube.	Check tube for cracks or leaks.
Oil and Pulse hoses reversed.	Check hose connections.
Low crankcase pressure.	Check pressure from pulse hose check valve (2 psi minimum).

**Problem: Warning Horn Does Not Sound When Ignition Key is Turned to “ON” Position.**

Possible Cause	Corrective Action
Horn malfunction or open (TAN) wire between horn and engine.	Use a jumper wire to ground TAN/BLUE lead (at engine terminal block) to engine ground. Warning horn should sound. If not, check TAN/BLUE wire between horn and engine for open circuit and check horn.
Faulty TKS ECM	Check if all TKS ECM leads are connected to harness leads. If so, module may be faulty.
Using incorrect side mount remote control or ignition/choke assembly.	See info on remote control Section 1D.

**Problem: Warning Horn Stays on When Ignition Key is Turned to “ON” Position.**

Engine overheat sensor	If horn sounds a continuous signal, the engine overheat sensor may be faulty. Disconnect overheat sensor and turn ignition key to “ON” position. If horn still sounds a continuous signal, the ECM is faulty. Replace module and re-test. If signal does not sound, then engine overheat sensor is faulty. Replace and re-test.
Faulty TKS ECM	Check connections – replace module.

**Problem: Warning Horn sounds when Engine is Running and Oil Level in Engine Reservoir is Full.**

Possible Cause	Corrective Action
Defective low oil sensor (located in fill cap of engine oil reservoir).	Do not remove cap from oil reservoir. Disconnect both low oil sensor leads from terminal connectors. Connect an ohmmeter between leads. There should be no continuity through sensor. If continuity exists, sensor is faulty. Replace cap assembly.

If all of the checks are positive, the ECM is faulty. Replace Module and re-test.



## Oil Pump Volume (Flow) Test

**NOTE:** The following specifications are determined with the engine running off a remote fuel supply with pre-mix fuel. The oil pump output hose (clear) must be disconnected from the input fuel line TEE fitting and directed into a graduated container. The input fuel line TEE fitting from which the oil line was removed **MUST BE CAPPED OFF** to prevent fuel leakage while the engine is running.

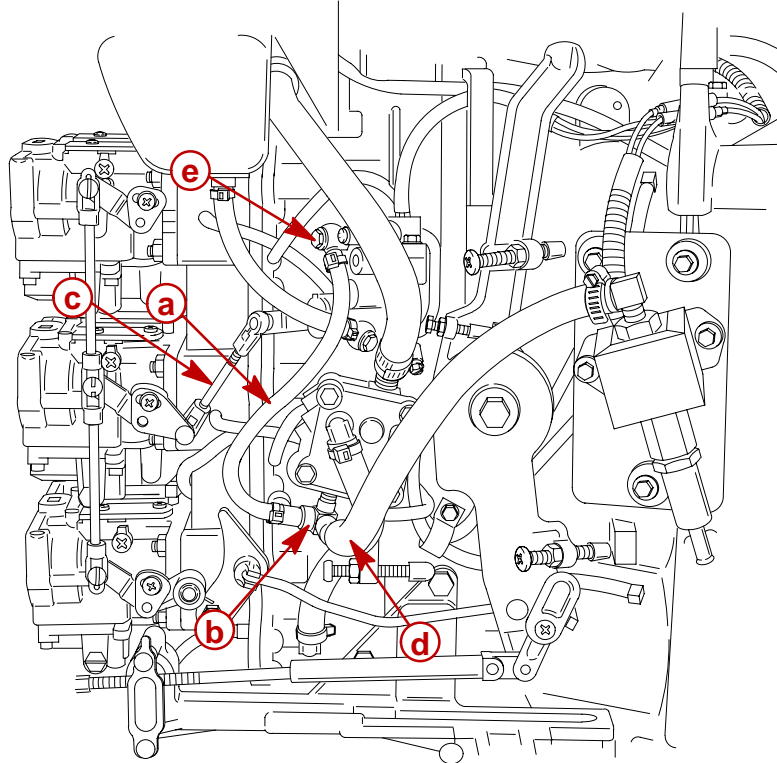

- a** - Oil Pump Output Hose (Clear)
- b** - Tee Fitting
- c** - Link Arm
- d** - Input Fuel Line
- e** - Oil Pump

Flow specifications are as follows:

@ 1000 RPM with oil pump link arm DISCONNECTED = 75cc  $\pm$  10% in 15 minutes



## Engine Mounted Oil Reservoir

### REMOVAL

**NOTE:** If oil reservoir contains oil, the clear oil hose going to the oil pump should be plugged upon removal to prevent oil spillage.

1. Disconnect input oil hose to oil reservoir.
2. Remove oil reservoir cap BLACK and LIGHT BLUE leads from their respective connections.
3. Disconnect clear input hose to oil pump and plug off hose.
4. Remove three bolts securing oil reservoir to powerhead and remove reservoir.

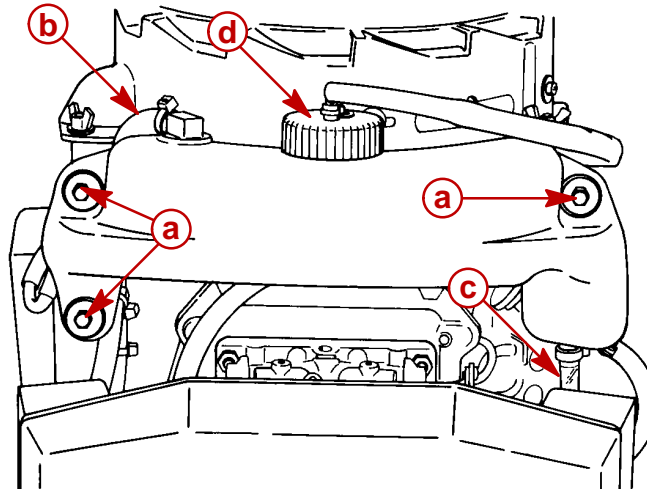

- a** - Bolts  
**b** - Input Oil Hose  
**c** - Oil Pump Input Hose (Clear)  
**d** - Oil Cap

### INSTALLATION

1. Apply Loctite 222 (obtain locally) to threads of 3 attaching bolts and secure oil reservoir to powerhead. Torque bolts to 25 lb. in. (2.8 N·m).
2. Install input oil hose to top of oil reservoir and secure with sta-strap.
3. Connect oil cap BLACK lead to engine ground and LIGHT BLUE lead to TKS ECM.
4. Connect clear output hose from oil reservoir to oil pump. Secure hose with sta-straps.